

Profibus-DP Interface for use with Brooks® Smart Mass Flow Meters models 5860S, 5861S, 5863S, 5864S & Mass Flow Controllers models 5850S, 5851S, 5853S



Essential Instructions

Read this page before proceeding!

Brooks Instrument designs, manufactures and tests its products to meet many national and international standards. Because these instruments are sophisticated technical products, you must properly install, use and maintain them to ensure they continue to operate within their normal specifications. The following instructions must be adhered to and integrated into your safety program when installing, using and maintaining Brooks Products.

- Read all instructions prior to installing, operating and servicing the product. If this instruction manual is not the correct manual, please see back cover for local sales office contact information. Save this instruction manual for future reference.
- If you do not understand any of the instructions, contact your Brooks Instrument representative for clarification.
- Follow all warnings, cautions and instructions marked on and supplied with the product.
- Inform and educate your personnel in the proper installation, operation and maintenance of the product.
- Install your equipment as specified in the installation instructions of the appropriate instruction manual and per applicable local and national codes. Connect all products to the proper electrical and pressure sources.
- To ensure proper performance, use qualified personnel to install, operate, update, program and maintain the product.
- When replacement parts are required, ensure that qualified people use replacement parts specified by Brooks Instrument. Unauthorized parts and procedures can affect the product's performance and place the safe operation of your process at risk. Look-alike substitutions may result in fire, electrical hazards or improper operation.
- Ensure that all equipment doors are closed and protective covers are in place, except when maintenance is being performed by qualified persons, to prevent electrical shock and personal injury.

ESD (Electrostatic Discharge)

CAUTION

This instrument contains electronic components that are susceptible to damage by static electricity. Proper handling procedure must be observed during the removal, installation or other handling of circuit boards or devices.

Handling Procedure:

1. Power to unit must be removed.
2. Personnel must be grounded, via a wrist strap or other safe, suitable means before any printed circuit card or other internal device is installed, removed or adjusted.
3. Printed circuit cards must be transported in a conductive container. Boards must not be removed from protective enclosure until immediately before installation. Removed boards must immediately be placed in protective container for transport, storage or return to factory.

Comments

This instrument is not unique in its content of ESD (electrostatic discharge) sensitive components. Most modern electronic designs contain components that utilize metal oxide technology (NMOS, SMOS, etc.). Experience has proven that even small amounts of static electricity can damage or destroy these devices. Damaged components, even though they appear to function properly, exhibit early failure.

Installation and Operation Manual

X-DPT-Profibus-Interface-eng

PN 541-C-068-AAG

November, 2008

Dear Customer,

We appreciate this opportunity to service your flow measurement and control requirements with a Brooks Instrument device. Every day, flow customers all over the world turn to Brooks Instrument for solutions to their gas and liquid low-flow applications. Brooks provides an array of flow measurement and control products for various industries from biopharmaceuticals, oil and gas, fuel cell research and chemicals, to medical devices, analytical instrumentation, semiconductor manufacturing, and more.

The Brooks product you have just received is of the highest quality available, offering superior performance, reliability and value to the user. It is designed with the ever changing process conditions, accuracy requirements and hostile process environments in mind to provide you with a lifetime of dependable service.

We recommend that you read this manual in its entirety. Should you require any additional information concerning Brooks products and services, please contact your local Brooks Sales and Service Office listed on the back cover of this manual or visit www.BrooksInstrument.com

Yours sincerely,

Brooks Instrument

CONTENTS

1	INTRODUCTION	6
1.1	How to use this manual	6
1.2	Related documents	6
1.3	Definition of terms	7
1.3.1	Terminology	7
1.3.2	Number representations and formats	8
2	PRODUCT OVERVIEW	9
2.1	General	9
2.2	Receipt of Equipment	9
2.3	Recommended Storage Practice	10
2.4	Return Shipment	10
2.5	Gas Connectionsl	10
2.6	The Brooks Smart Mass flow products	11
2.7	Profibus on the Smart TMF series	12
3	INSTALLATION	14
3.1	Installation	14
3.2	Electrical interfacing	14
3.2.1	General	14
3.2.2	Main connector	14
3.2.3	Additional Profibus connector (5800 series)	16
3.2.4	Main connector (MF series)	17
3.2.5	Profibus connector (MF series)	18
3.3	Station address selection	18
3.4	Zero pushbutton	19
3.5	Supported baud rates	19
3.6	Profibus network wiring	20
3.6.1	Profibus network wiring requirements	20
3.6.2	Line termination requirements	21
3.6.3	Special requirements for high-speed communication	21
4	SLAVE CONFIGURATION	23
4.1	Introduction	23
4.2	Illustration of the Profibus-DP communication procedure	23
4.3	Parameterization of the slave (MFC)	23
4.4	Configuration of the slave	29
4.5	Diagnostic	31
4.5.1	Device diagnostic Message	31
4.5.2	Run-time message errors	31
4.5.3	Fatal system errors	32
4.5.4	Primary non-fatal system errors	32
4.5.5	Secondary non-fatal system errors	34
4.5.6	Non-fatal ambient errors	34
4.6	Data Exchange Mode	35
4.7	Example of the Profibus-DP communication procedure	38
5	MODELLISTING	39
	APPENDIX A PROFIBUS-DP MESSAGE SERVICES	47
A.1	Global control commands	47
A.2	Fail-safe option	47
A.3	Sync/unsync option	47
	APPENDIX B IEEE 754 FLOATING POINT FORMAT	49

TABLES

Table 2-1: Brooks Smart Mass Flow Meters and Controllers.....	11
Table 3-1: Smart TMF main connector pin layout.....	15
Table 3-2: Smart TMF Profibus-DP network connector pin layout.....	16
Table 3-3: Supported baud rate values.....	20
Table 3-4: Profibus cable parameters.....	20
Table 5-1: Diagnostics message, extended data section layout.....	31
Table 5-2: Diagnostics: Run-time message error bits.....	31
Table 5-3: Diagnostics: Fatal system error bits.....	32
Table 5-4: Diagnostics: Primary non-fatal system error/alarm bits.....	33
Table 5-5: Diagnostics: Secondary non-fatal system error/alarm bits.....	34
Table 5-6: Diagnostics: Non-fatal ambient error/alarm bits.....	34

Figures

Figure 3-1: Smart TMF main 15-pin male sub-D connector - pin numbering.....	15
Figure 3-2: Profibus 9-pin female sub-D connector - pin numbering	16
Figure 3-3: MF Profibus Main Power Connection	17
Figure 3-4: Pin numbering	18
Figure 3-5: Smart Mass Flow Meter/Controller - Outlet view	18
Figure 3-6: Profibus line termination configuration	21
Figure 3-7: Recommended TEE and Terminator Resistor	21
Figure 3-8: High-speed communication inductors	22

1 Introduction

1.1 HOW TO USE THIS MANUAL

This instruction manual is intended to provide the user with all the necessary information to operate and program the Brooks Instrument Smart Mass Flow Meters and Controllers on a Profibus-DP network. This manual should be used together to the *Installation and Operating Manual Smart TMF series* (Brooks Instrument doc. #541-C-051), which covers the installation, operation and maintenance of Smart Mass Flow devices with respect to their intended use in a gas flow system.

This manual covers the additional device features as well as the installation and programming issues with respect to operating the Smart TMF series devices on a Profibus-DP network.

This manual is organized in to five sections:

Section 1: Introduction

Section 2: Product overview

Section 3: Installation

Section 4: Slave configuration

Section 5: Modelling

Appendix A: Profibus-DP message services

Appendix B: IEEE 754 floating point format

Appendix C: Warranty & Repair sheet

It is recommended that this manual is read in its entirety, before connecting the device to the network and attempting to operate it over the network.

1.2 RELATED DOCUMENTS

The following documents are referred to in this document or are suggested for further reading:

1. *Installation and Operating Manual Smart series TMF* - Brooks Instrument, doc. #541-C-051
2. *Installation and Operating Manual MF series* - Brooks Instrument, doc. #541-C-061
3. *Installation and Operating Manual Smart-Control software* - Brooks Instrument, doc. #541-C-054
4. *Installation and Operating Manual Smart DDE software* - Brooks Instrument, doc. #541-C-057
5. EN 50170 (DIN 19245 Part 1) - *General Profibus standard* (PNO doc. #0.002)
6. EN 50170 (DIN 19245 Part 3) - *Profibus-DP standard* (PNO doc. #0.012)
7. Profibus Interconnection Technology *Profibus Guide line* (PNO doc. #2.142)
8. *Implementierungshinweise zur DINE 19245 Teil 3* (German, PNO doc. #2.041)
9. *Simatic-Net SPC3 Siemens PROFIBUS Controller - User Description, v1.5, 10/96*, Siemens AG 1996, document 6ES7-195-0BD00-8BA0.
10. *The rapid way to Profibus-DP*. M. Popp, 1997 (PNO doc. 4.072)

The PNO document numbers between brackets, refer to the PNO (German Profibus User Organization) documentation list.

1.3 DEFINITION OF TERMS

1.3.1 Terminology

GSD file	The GSD file contains the characteristic device data of the product, i.e. the device profile.
Input/Output	Profibus-DP conventions define all input/output directions as seen from the master system. Data transferred by the master to the slave (e.g. commands, setpoints) is referred to as ' output data '. Slave (sensor) data to be transferred to the master is referred to as ' input data '.
Motherboard	Main electronics board of the Smart TMF series containing the main processor, sensor and valve interface and main connector.
Piggyback	Exchangeable board on top of and connected to the main board. This board provides the communications functionality and holds the program and data memory.
PNO	Profibus Nutzer Organization . Profibus User Organization, based in Germany.
Profibus-FMS	Process field bus - Fieldbus Message Specification . Profibus protocol for high-level, object oriented data communication. Can be operated together with Profibus-DP.
Profibus-DP	Process field bus - Decentralized Periphery . Profibus protocol for high-speed, cyclic data communication.
Profibus-PA	Process field bus - Process Automation . Profibus protocol for intrinsically safe data communication, according to IEC1158-2 and DIN E19245 T4.
SPC3	Profibus-DP ASIC. Component manufactured by Siemens AG to provide Profibus-DP slave functionality to a host processor.
MFC	Mass Flow Controller
MFM	Mass Flow Meter

1.3.2 Number representations and formats

Bit	Smallest binary information representation: 0 or 1
Nibble	Binary number representation, consists of 4 bits. Represents 1 value or 4 situations ('bitmapped'). Usually nibbles appear grouped together in one or more bytes (i.e. two per byte). Examples: Value: binary 0011 = 3 decimal Bitmapped: binary 0111 = bits 0,1, and 2 are true, 3 is false
Byte or Octet	Binary number representation, consists of 8 bits. Represents 1 value or 8 situations ('bitmapped'). Bits in a byte are numbered from right to left, i.e. least significant bit is bit 0, most significant bit is bit 7. Examples: Value: binary 00110011 = 51 decimal Bitmapped: binary 00010111 = bits 0,1,2 and 4 are true, others are false
Word	Combination of 2 bytes or 16 bits. Represents 1 value or 16 situations ('bitmapped'). Examples: Value: binary 00010001 00110011 = 4404 decimal Bitmapped: binary 00010001 00010111 = bits 0,1,2,4,8 and 12 are true, others are false.
Integer	An integer is a whole number (not a fractional number) that can be positive, negative, or zero. Examples: -5, 1, 5, 8, 97, and 3,043.
Decimal	Common numbers in the decimal number system. Range depends on size of the binary representation: Examples: 1 binary byte: range 0..255 decimal 2 binary bytes = 1 binary word: range 0..65535
Hexadecimal	Representation of numbers in the hexadecimal number system. Any written hexadecimal number in this manual is preceded by "0x" Examples: 0x25 = hexadecimal 25 = decimal 37 (1 byte) 0xB4 = hexadecimal B4 = decimal 180 (1 byte)
Real	Representation of fractional numbers according to IEEE-754 single precision floating point format definition. See also Appendix B Size: 4 bytes Range: $\pm 3.4 \cdot 10^{-38}$ to $\pm 3.4 \cdot 10^{+38}$ Examples: 0x41 0x45 0x70 0xA4 = decimal 12.34

2 PRODUCT OVERVIEW

2.1 General

This section contains the procedures for the receipt and installation of the instrument. Do not attempt to start the system until the instrument has been permanently installed. It is extremely important that the start-up procedures be followed in the exact sequence presented.

NOTE: Operating procedure: do not operate this instrument outside the specification range listed in section 5.

Before bringing the unit into operation, make sure that all gas connections have been correctly tightened and that all the necessary electrical connections have been made.

2.2 Receipt of Equipment

When the equipment is received, the outside packing case should be checked for damage incurred during shipment. If the packing case is damaged, the local carrier should be notified at once regarding his liability. A report should be submitted to your nearest Product Service Department.

Brooks Instrument

407 W. Vine Street
P.O. Box 903
Hatfield, PA 19440 USA
Toll Free (888) 554-FLOW (3569)
Tel (215) 362-3700
Fax (215) 362-3745
E-mail: BrooksAm@BrooksInstrument.com
<http://www.brooksinstrument.com>

Brooks Instrument

Neonstraat 3
6718 WX Ede, Netherlands
P.O. Box 428
6710 BK Ede, Netherlands
Tel 31-318-549-300
Fax 31-318-549-309
E-mail: BrooksEu@BrooksInstrument.com

Brooks Instrument

1-4-4 Kitasuna Koto-Ku
Tokyo, 136-0073 Japan
Tel 011-81-3-5633-7100
Fax 011-81-3-5633-7101
E-mail: BrooksAs@BrooksInstrument.com

Remove the envelope containing the packing list. Carefully remove the instrument from the packing case. Make sure spare parts are not discarded with the packing materials. Inspect for damaged or missing parts.

2.3 Recommended Storage Practice

If equipment supplied by Brooks Instrument is to be placed in intermediate or long-term storage, it is recommended that it be:

- a. Stored within the original shipping container.
- b. Stored in a sheltered area, under the following conditions:
 - 1) Optimum ambient temperature 21°C (70 °F), maximum 32 °C (90 °F), minimum 7 °C (45 °F),.
 - 2) Optimum relative humidity 45% (maximum 60%/minimum 25%).
- c. Subjected to a visual inspection upon removal from storage, to verify that the condition of the equipment is 'as received'. If the equipment has been in storage for more than ten months or if it has not been stored under the recommended conditions, all pressure containing seals should be replaced. In addition, the device should be subjected to a pneumatic pressure test in accordance with the applicable vessel codes.

2.4 Return Shipment

Prior to returning any instrument to the factory, contact your nearest Brooks location for a Return Materials Authorization Number (RMA#). This can be obtained from one of the following locations:

Brooks Instrument

407 W. Vine Street
P.O. Box 903
Hatfield, PA 19440 USA
Toll Free (888) 554-FLOW (3569)
Tel (215) 362-3700
Fax (215) 362-3745
E-mail: BrooksAm@BrooksInstrument.com
<http://www.brooksinstrument.com>

Brooks Instrument

Neonstraat 3
6718 WX Ede, Netherlands
P.O. Box 428
6710 BK Ede, Netherlands
Tel 31-318-549-300
Fax 31-318-549-309
E-mail: BrooksEu@BrooksInstrument.com

Brooks Instrument

1-4-4 Kitasuna Koto-Ku
Tokyo, 136-0073 Japan
Tel 011-81-3-5633-7100
Fax 011-81-3-5633-7101
E-mail: BrooksAs@BrooksInstrument.com

Any instrument returned to Brooks requires completion of Form RPR003-1, Brooks Instrument Decontamination Statement, as well as, a Material Safety Data Sheet (MSDS) for the fluid(s) used in the instrument. This is required before any Brooks Personnel can begin processing. Copies of the form can be obtained from any Brooks Instrument location listed above.

2.5 Gas Connections

All models are fitted with the following inlet and outlet connectors as standard: NPT(F), tube compression fittings, VCR, VCO, DIN or ANSI flanges. Prior to installation, make certain that all piping is clean and free of obstruction. Install the piping in a manner that permits easy access to the instrument, should it need to be removed for cleaning or test-bench troubleshooting.

2.6 THE BROOKS SMART MASS FLOW PRODUCTS

The Brooks Smart Mass Flow Meters, models 5860/MF60, 5861/MF61, 5863/MF63 and 5864/MF64 measure gas flow accurately. The heart of the system, is the thermal mass flow sensor which produces an electrical output signal as a function of flow rate. In addition the Brooks Smart Mass Flow Controllers, models 5850/MF50, 5851/MF51 and 5853/MF53 are equipped with an electro-mechanical valve, allowing them to control gas flows. The flow ranges per model are listed in Table 2-1 below.

Table 2-1: Brooks Smart Mass Flow Meters and Controllers.

Brooks Smart Mass Flow Products				
Mass Flow Controller Model	Mass Flow Meter Model	Flow Ranges (N ₂)		
		Min. full scale	Max. full scale	Unit*
5850/MF50	5860/MF60	0.003	30	l _n /min
5851/MF51	5861/MF61	20	100	l _n /min
5853/MF53	5863/MF63	100	2500/1000	l _n /min
	MF64	18	2160	m _n ³ /hr

* The index n refers to 'normal' conditions, i.e. 0°C, 1013.25 mbar.

Standard features of the Brooks Smart series include:

- High accuracy and repeatability.
- Selectable analogue setpoint input/flow rate output signals.
- Adaptive signal filtering.
- Fast response to setpoint changes.
- Programmable softstart ramp rate.
- Powerful adaptive control to provide optimal control behaviour and response under varying process conditions.
- Programmable valve override function.
- Programmable totalizer function.
- High-Low flow alarms.
- Continuous self diagnostics to ensure system integrity as well as signal diagnostics to ensure process integrity.
- Programmable alarm signalling options.
- Selectable communication protocol options.

The electronics as used on these models consist of the following printed circuit boards:

1. a motherboard, containing the main processor, the calibration database, the sensor and signal I/O, valve drive, power supply conditioning and the main 15-pin sub-D connector, and
2. a piggyback board on top of the motherboard containing the program memory and optional digital communication hardware.
3. MF series only: a terminal connector board for termination of the power supply and profibus connections.

The standard piggyback board (part number 097-B-225-ZZZ) contains all the necessary hardware and software to implement the standard HART based digital communication protocol, providing access to all calibration data as well as actual data, diagnostics and alarms. The hardware allows the protocol to be operated on either RS-232 or RS-485 (dip switch selectable) and on a number of baud rates (1200 baud up to 38400 baud). Windows based software is available to facilitate communication with a PC (Refer to *Installation and Operating Manual Smart-Control software* - doc. #541-C-054 and *Installation and Operating Manual Smart DDE software*, doc. #541-C-057 for more information).

A second type of piggyback board (part number 097-B-296-ZZZ) is now available containing all the necessary hardware and software to implement the Profibus-DP digital communication protocol, providing access to a (limited) number of settings, the actual data, diagnostics information and alarms. The Profibus-DP implementation, as defined in the Profibus standard EN 50170, allows the Smart TMF series to be connected to an RS-485 network and to be operated from a master device (e.g. a PLC) using the Profibus-DP protocol at communication speeds of up to 12 Mbaud.

Both piggyback boards are interchangeable, and provide the same control, analogue I/O, diagnostics, and alarm functions as well as accuracy and performance. Also since the database is located on the motherboard the calibration will not be affected by changing the piggyback board. The next section will discuss the Profibus-DP features and function in more detail.

2.7 PROFIBUS ON THE SMART TMF SERIES

The Profibus piggyback board on the Brooks Smart TMF series is provided with all the necessary hardware and software to implement Profibus-DP functionality on an RS-485 network according to the EN 50170 Profibus standard. The Profibus piggyback board is equipped with an additional 9-pin sub-D connector for the 58.. series and M12 connector for the MF series, and is galvanic isolated from the main electronics as defined by EN 50170, to allow easy connection to the network, separate from the main connector. The main 15-pin sub-D connector or termination board is still needed for the power supply, but also allows for the standard analogue I/O signals, analogue valve override and (open-collector) alarm signalling to be used separately from the network connection. On the MF series no I/O and alarm output signals are available.

Communication can be performed at a number of baud rates ranging from 9600 baud up to 12 Mbaud. The communication electronics allows for automatic baud rate detection, thus making the need for any hardware baud rate selection methods not required. For selecting the device address, which must be unique on the network, two rotary switches are provided. This allows a user to easily select any address number ranging from 0 to 126, also providing the possibility for fast device replacement, without the need for complex network configuration.

The PROFIBUS-DP communication option supports the following message types:

- Cyclic data exchange (Write/Read data).
- Read inputs (e.g. status, flow, temperature, totalizer, etc.).
- Read outputs (e.g. commands, setpoint).

Installation and Operation Manual

X-DPT-Profibus-Interface-eng

PN 541-C-068-AAG

November, 2008

- Global control commands (e.g. fail safe, sync).
- Get configuration (i.e. read number of I/O bytes and composition).
- Read diagnostics information (i.e. get error and alarm status).
- Set parameters (i.e. select gas number, engineering units, I/O configuration).
- Set parameters (i.e. select gas number, engineering units, I/O configuration etc.).
- Check configuration (i.e. check I/O composition).

These message types provides the user with the possibility to select a number of operational settings, as well as to define which actual data are to be exchanged in the data exchange mode. This allows for the selection of only a minimum of (required) data to be exchanged, thus conserving memory at the master or for the selection of all the actual data. Diagnostics information can be obtained when needed, providing information on device and process integrity as well as communication integrity.

Additional features not available on the standard communication protocol include fail safe option (i.e. pre-programmed device behaviour in case of a network failure) and sync/unsync, allowing for synchronized behaviour for a group of devices.

Calibration data as well as device data are not available through the Profibus-DP communication, but will require a standard communication piggyback board. Also Profibus-DP/V1 (extended Profibus-DP implementing a-cyclic data transfer), or Profibus-FMS functionality are not implemented, although they can be operated on the same network. Profibus-PA functionality, providing data transfer on intrinsically safe networks is also not supported.

Finally the Profibus-DP piggyback board is equipped with a zero command pushbutton, allowing the user to give a manual command to the device to (re)balance the flow sensor electronics. This command can also be issued through the protocol.

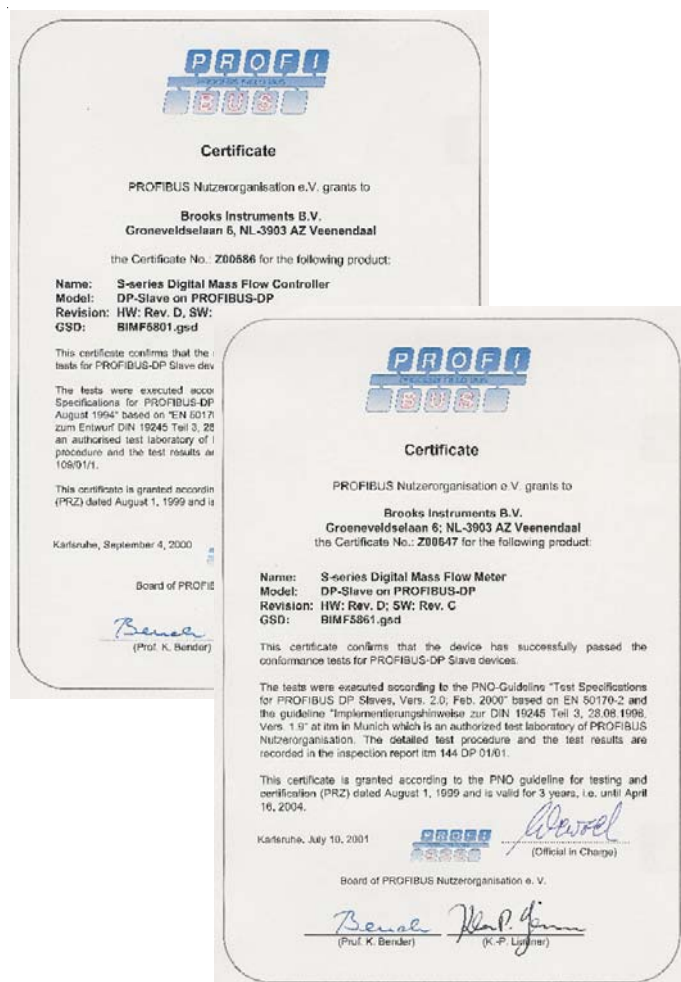

3 Installation

3.1 INSTALLATION

This section discusses the installation requirements for the Smart Mass Flow Meter/Controller models equipped with the Profibus-DP interface. It will focus only on the installation requirements necessary to operate the device on a Profibus network as well as on other issues, related to this interface. The reader is referred to the *Installation and Operating Manual Smart TMF series* (Brooks Instrument, doc. #541-C-051) for general installation and operating instructions of the device in the gas flow measurement/control application as well as for further information on standard electrical interfacing.

3.2 ELECTRICAL INTERFACING

3.2.1 General

All Brooks Smart TMF devices are equipped with a male 15-pin sub-D connector, providing all the necessary connections to operate the device at least in an analogue way. This allows the device to be used as a simple plug-in replacement for earlier analogue mass flow meter/controller models, offering the improved performance and additional features of the digital implementation. Two pins on this connector, pin 14 and 15, are reserved for the connection of a digital communications protocol. Whether these pins are used for this purpose, will depend on the type of piggyback board installed. The standard piggyback board will offer HART based communication over either RS-232 or RS-485 through these pins. If these pins are not used, the installed piggyback will have to provide a separate interface (connector) to allow connection to the network.

In the case of the Profibus-DP interface for the Brooks Smart Mass Flow Meter/Controller models, pin 14 and 15 on the main connector are not used. The installed piggyback board will provide a separate connector for network connections. This connector is a female 9-pin sub-D connector, specified by the Profibus standard as the preferred connector (refer to EN 50170, part 1). Pin layout on this connector is according to this standard.

NOTE: The presence of this separate connector does NOT make the main connector redundant. The main connector must at least be used to provide the necessary power to the device. In addition however, all the other, non-communication related functions are still available through this main connector.

3.2.2 Main connector (5800 series)

The male 15-pin sub-D connector provides all necessary functionality to operate the device. Despite the presence of a Profibus network connection, all the pins, except for pin 14 and pin 15, retain their functionality and they can still be used. For some pins the functionality is selectable (ON/OFF), whereas other pins can be used in parallel to the network connection. This allows the device to be used as a plug-in replacement for an analogue mass flow meter or controller with the Profibus-DP communication in a monitoring role. It can however also be used as a Smart Mass flow meter/controller, fully driven through the network connection. Also a mix of both is possible. Figure 3-1 shows the pin layout and numbering of the main connector. Table 3-1 lists the pin-configuration of the main 15-pin sub-D connector.

Figure 3-1: Smart TMF main 15-pin male sub-D connector - pin numbering.

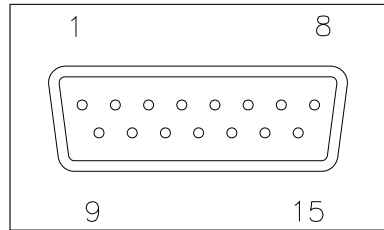

Table 3-1: Smart TMF main connector pin layout.

Pin number	Function	
	Models 5850S, 5851S, and 5853S	Models 5860S, 5861S, 5863S and 5864S
1	Setpoint return (-)	Not used
2	0(1) - 5 Vdc Flow signal output	0(1) - 5 Vdc Flow signal output
3	(TTL) Open collector alarm output	(TTL)Open collector alarm output
4	0(4) - 20 mA Flow signal output	0(4) - 20 mA Flow signal output
5	+24 Vdc Power supply	+24 Power supply
6	Not used	Not used
7	0(4) - 20 mA Setpoint input	Not used
8	0(1) - 5 Vdc Setpoint input	Not used
9	Power supply common	Power supply common
10	Flow signal output common	Flow signal output common
11	+5Vdc reference output	Not used
12	Valve override input	Not used
13	Not connected	Not connected
14	RS-232 RxD/RS-485 A- **	RS-232 RxD/RS-485 A- **
15	RS-232 TxD/RS-485 A+ **	RS-232 TxD/RS-485 A+ **

* Not connected indicates “not electrically connected internally”. Not used indicates “electrically connected internally, but serves no purpose”.

** Pin 14 and 15 are connected through to the piggyback board and are reserved for the digital communication option in case the standard piggyback is installed. In case the Profibus-DP piggyback is installed, these pins are not connected.

The minimum requirement to operate the device on a Profibus network is the connection of the power supply lines, pin 5 (+15 Vdc to +28Vdc) and pin 9 (power supply common). For Profibus usage only +24V power supply option is used (refer to the *Installation and Operating Manual Smart TMF series*, doc. #541-C-051 and #541-C-061 for MF version).

The analogue output signals, representing a measure for the flow on pin 2 (voltage output), pin 4 (current output) and pin 10 (flow signal output common) can be used in parallel with the network. Information on the flow can be obtained through the network (in engineering units), but at the same time as a voltage or current level through pin 2, 4 and 10. However, these pins can also be set to OFF through the network, forcing them to the 0 volt/current level.

The setpoint command (Smart Mass Flow Controller models only), can be issued either through the Profibus network or through an analogue signal level. The user has to define the setpoint source and (in the case of an

analogue signal input) the setpoint level through the network. If the setpoint command is to be issued through an analogue level on pin 7 (current input) or pin 8 (voltage input) and pin 1 (setpoint return signal), it can be monitored over the Profibus network at the same time. If the setpoint command is issued over the Profibus network, any analogue setpoint signal on pin 7 or 8 is ignored.

The valve override input signal on pin 12 (Smart Mass Flow Controller models only) can always be used in parallel to the network. The command issued through pin 12 (OPEN or CLOSE) always takes precedence over the network valve override command. If the level on pin 12 is left floating (not connected) a valve override command issued through the network connection will be carried out.

The TTL open collector alarm output (pin 3) can always be used in parallel with the network. Any (enabled) system diagnostics signalling will activate the alarm output and simultaneously result in a diagnostics message through the network.

3.2.3 Additional Profibus connector (5800 series)

The Profibus-DP piggyback board is equipped with a separate female 9-pin sub-D connector. The connector type as well as the pin layout is compatible with the preferred connector as stated in the Profibus standard EN 50170. This allows for the use of standard available, Profibus approved network connectors, enabling fast and easy connection to a Profibus network. Table 3-2 below shows the pin numbering on the female 9-pin sub-D Profibus connector. The connector is located on top of the Smart Mass Flow device.

Figure 3-2: Profibus 9-pin female sub-D connector - pin numbering.

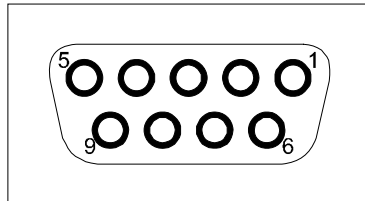

Table 3-2: Smart TMF Profibus-DP network connector pin layout

Pin nr.	Signal	Function	
		Smart TMF series Profibus-DP connector	EN 50170 standard definition
1	Shield	Connected to housing	Shield/protective ground
2	M24	Not connected	Ground of 24 Vdc powersupply
3	RxD/TxD-P	RxD/TxD - A+	RxD/TxD - A+
4	CNTR-P	Not connected	Control signal for repeaters (direction control)
5 DGND	Digital ground for terminating resistance	Digital ground for terminating resistance	Digital ground for terminating resistance
6	VP	Digital +5 Vdc supply for terminating resistance	Digital +5 Vdc supply for terminating resistance
7	P24	Not connected	24 Vdc power supply
8	RxD/TxD-N	RxD/TxD - A-	RxD/TxD - A-
9	CNTR-N	Not connected	Control signal for repeaters (direction control)

Signals in bold type face are mandatory according to EN 50170.

Signal names are according to EN 50170.

Installation and Operation Manual

X-DPT-Profibus-Interface-eng

PN 541-C-068-AAG

November, 2008

The connector provides the four mandatory signals as defined in EN 50170, i.e. RxD/TxD-P, RxD/TxD-N, VP and DGND. The other defined signals, the 24 Vdc power supply option as well as the optional repeater control signals, are not supported and therefore not connected on the Smart TMF series Profibus piggyback board. The Profibus signals are galvanic isolated from the main electronics.

The required line termination is not provided within the Smart TMF series device itself. Refer to section 3.4 for network wiring instructions.

3.2.4 Main connector (MF series)

The MF series have a PG11 connector at the inlet side of the mass flow device for the power supply and analogue I/O. In case of profibus no analogue I/O is possible, except for the Valve OverRide (VOR) input. In these cases this PG11 connector is solely used for the power supply connection and the VOR input signal. Figure 3-3 shows the terminal connection location for power supply and V.O.R. the power connection (as well as the profibus connection terminals) can be accessed by opening the top cover plate by removing the four bolts on the top of the cover plate.

The minimum requirement to operate the device on a Profibus network is the connection of the power supply lines, labeled +24V and GND.

Figure 3-3: MF Profibus Main Power Connection

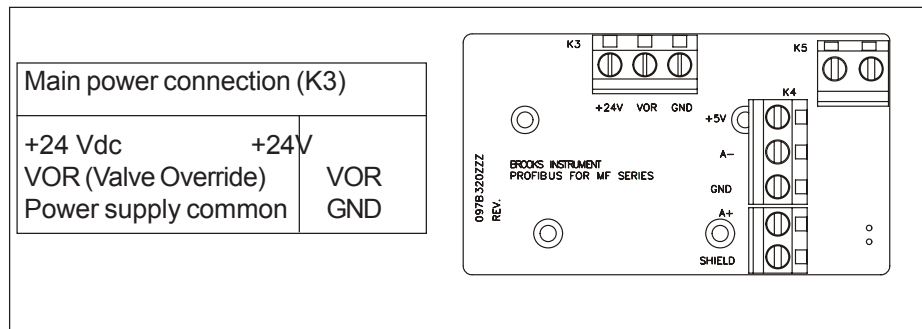

The valve override signal, middle screw terminal labeled VOR, can always be used in parallel to the network. The command (OPEN, or CLOSE) issued through this VOR terminal always takes precedence over the network valve override command. If the level on this terminal is left floating (not connected) a valve override command issued through the network will be carried out.

NOTE: With regard to the power supply connections, the attached cable must be as short as possible to ensure that the minimum required voltage and current is available at the mass flow device.

Cable Shielding Earth

Cable requirements

Compliance with EMC directive 89/336/EEC, requires that the equipment be fitted with fully screened cables with at least 80% shielding. The cables with at least 80% shielding. The cable shielding should be connected to the PG connector's metal shell, and have 360 shielding at both ends. The shielding should be connected to an earth terminal.

For translations of this instruction, see Appendix D of the MF series Instruction and Operation manual p.n. #541-C-061-AAG: Translations of installation instructions.

3.2.5 Profibus connector (MF series)

The Profibus-DP electronics is hooked up via a separate M12 connector on top of the device. This connector has IP65 protection rate and is defined in the Profibus guideline 2.142: Interconnection Technology Specifications. This allows for the use of standards available, Profibus approved network connectors, enabling fast and easy connection of a Profibus network. Figure 3-4 below shows the pin numbering. The connector provides the four mandatory signals as defined in the EN 50170, i.e. RxD/TxD-P, RxD/TxD-N, VP and DGND. The Profibus signals are galvanic isolated from the main electronics. The fifth connector terminal is the shieldings.

Figure 3-4: Pin numbering

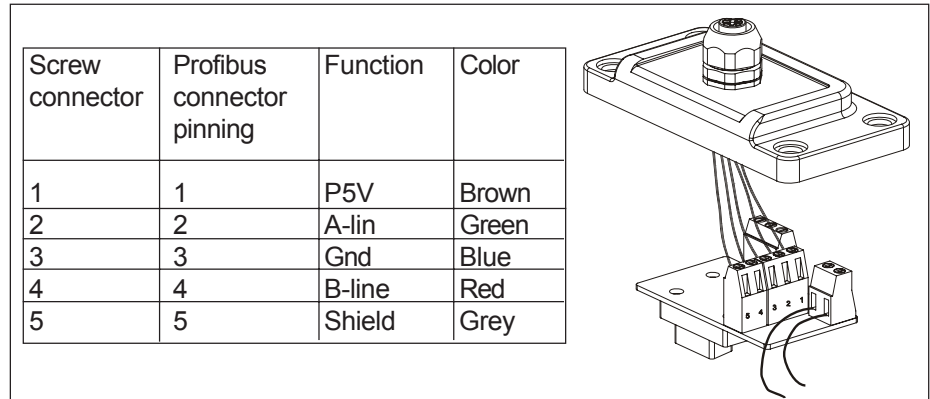

3.3 STATION ADDRESS SELECTION

In order for a Profibus network master device to be able to address individual slave devices on the network, a slave device will require the assignment of a unique communication address or station address. This must be done prior to being connected to the network. The slave address can be 126 at maximum since 127 is the Global Station Address.

On the Profibus interface piggyback for the Brooks Smart TMF devices, the station address selection is implemented by two rotary switches, located on the side of the device (location of the valve), refer to Figure 3-5 below. Each of the switches allow a setting of an integer number, the units between 0 and 9 and the decimals 0 and 12. The decimal address digit indicates the multiples of ten, whereas the unit address digit indicates the multiples of one. Therefore the allowable station address number ranges from 0 to 126.

The decimal switch has a labelling from 0 through F, which is hexadecimal. The letters A through F represents 10 through 15. The letter D, E and F are not allowed since they represent addresses in the range 130, 140 and 150, which is outside the Profibus range of 126. If the total address selection is 126 or higher, the slave address is 126.

Figure 3-5: Smart Mass Flow Meter/Controller - Profibus connection

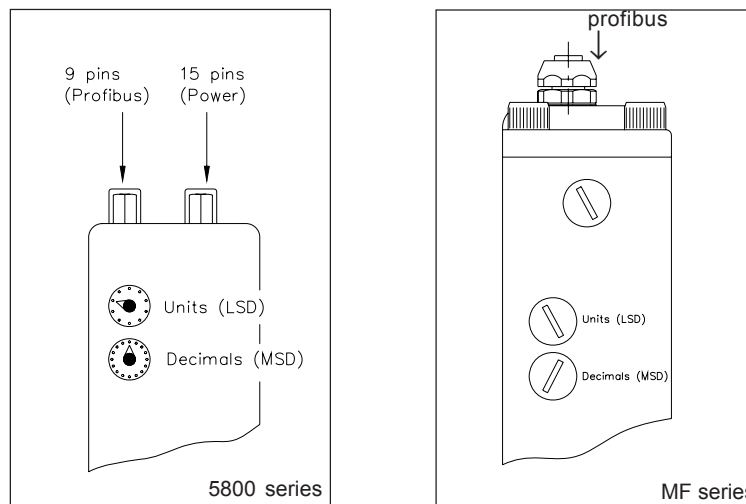

The Profibus-DP standard EN 50170 also defines the option of setting the station address through communication. This option has been disabled in the Brooks Smart TMF series.

On top of this unique address number each slave uses three other address numbers:

- 1. Identity number:** This number is a unique, fixed, WORD size number assigned by the Profibus Organization PNO to each type or class of devices. It is programmed in the device's source code and it is used to establish the link between the class of devices and its associated GSD file. It is by standard definition part of the addressing mechanism and as such part of every communication service.
- 2. Global station address:** This station address, number 127, is a Profibus defined address to be used in the transmission of global control command messages. All slave devices connected to a network will recognize this number as a valid address. Whether they will act up on this command when received will depend on the third addressing option, which must be used together with this global station address.
- 3. Group number:** An additional address number can be assigned by the user to a group of (different) devices. This group number, one byte in size must be set as part of the parameterization service. It can be used in the global command service next to the global station address, to send command to a (sub) group of devices on a network. Refer to section Appendix A for more information.

3.4 ZERO PUSHBUTTON (only for 5800 series)

In order to be able to initiate a sensor zero request to (re)balance the flow sensor, the device is equipped with a pushbutton. Pressing this button will cause the processor to perform the necessary action to accomplish this. The action can also be initiated through the protocol, by setting the appropriate bit flag in the first command byte.

The zero pushbutton is located on the opposite side of the Profibus-DP address selector switches on the Brooks Smart TMF device. To achieve a valid (re)-balance of the flow sensor, take the following actions:

1. Make sure the device has been fully warmed up after power-up, i.e. it should be powered up for at least 45 minutes.
2. Make sure that no gas flow through the device is present. If there has been any gas flow through the device after power-up, leave the device without gas flow for 15 minutes, in order to stabilize the sensor.
3. Press the zero pushbutton and wait for 10 seconds. After that, the (re)balancing of the sensor has been completed and the device is ready to be used. Now gas flow can be (re)applied to the device

3.5 SUPPORTED BAUD RATES

Since the Profibus-DP interface has been implemented using the Siemens SPC3 Profibus-DP slave ASIC, the baud rates supported are determined by the capabilities of this component. The baud rates supported are listed in Table 3-3 below (Refer to doc. 6ES7-195-0BD00-8BA0: *Simatic-Net SPC3 Siemens PROFIBUS Controller - User Description, v1.5, 10/96, page 19, Siemens AG 1996*).

The SPC3 also supports automatic baud rate detection. Therefore no hardware means are necessary to select the required baud rate at the slave. Communication initiated by the master at a any of the supported baud rate values will cause the Brooks Smart TMF series device to lock on to this baud rate after an automatic search for it. Also, if no valid messages have been detected on the network after a pre-programmed time out, the Brooks Smart TMF series will switch to baud search mode, and search for the correct baud rate until found.

Table 3-3: Supported baud rate values.

Baud rate	Max. response time	Max. cable segment length
12 Mbaud	67 µsec (800 Tbit [*])	100m/327 feet
6 Mbaud	75 µsec (450 Tbit [*])	100m/327 feet
3 Mbaud	83 µsec (250 Tbit [*])	100m/327 feet
1.5 Mbaud	100 µsec (150 Tbit [*])	200m/655 feet
500 kBaud	200 µsec (100 Tbit [*])	400m/1311 feet
187.5 kBaud	320 µsec (60 Tbit [*])	1000m/3278 feet
93.75 kBaud	640 µsec (60 Tbit [*])	1200m/3934 feet
45.45 kBaud ^{**}	8.8 msec (400 Tbit [*])	1200m/3934 feet
19.2 kBaud	3.125 msec (60 Tbit [*])	1200m/3934 feet
9600 Baud	6.25 msec (60 Tbit [*])	1200m/3934 feet

* Tbit is the time required to send 1 data bit, at the associated bit rate. Refer to standard EN 50170.

** 45.45 kBaud is only used for Profibus-DP and Profibus-PA systems with coupling devices.

3.6 PROFIBUS NETWORK WIRING

3.6.1 Profibus network wiring requirements

The physical network connection with Brooks Smart TMF devices to be used with Profibus-DP communication is based on RS-485. The standard EN 50170 specifies the type of cable to be used for this implementation. Table 3-4 below lists the required cable parameters as specified by EN 50170.

The Profibus cable is a shielded twisted pair cable. The shielding must be connected to protective ground (i.e. conductive housing on Brooks Smart TMF series devices) in order to prevent EMC interference from entering the device.

Table 3-4: Profibus cable parameters

Parameter	Line type A	Unit
Impedance	135 to 165	[Ω]
Capacitance per unit length	< 30	[pF/m]
Loop resistance	110	[Ω/km]
Core diameter	0.64	[mm]
Core cross section	> 0.34	[mm ²]

3.6.2 Line termination requirements

Line termination on RS-485 is defined by EN 50170 and should be provided at the start and at the end of each network cable segment. Figure 3-3 below shows the line termination configuration at the start/end of a network cable segment.

Figure 3-6: Profibus line termination configuration.

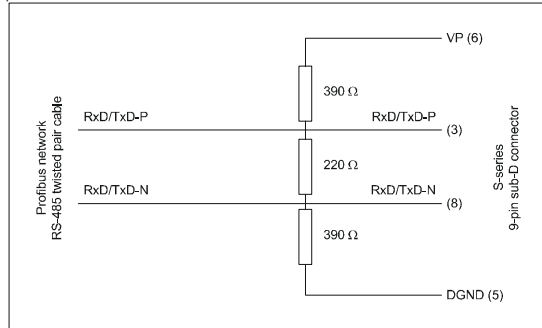

The Brooks Smart TMF series does not provide internal termination resistors. Therefore, if required at the connector of a Smart TMF series device (e.g. because it is at the end of a network cable segment) the termination resistors have to be provided through the connector on the network cable.

Special Profibus connectors, with build-in line termination resistors, which can be switched on or off, are available from a number of vendors (e.g. Siemens, Erni Components etc.). These connectors usually provide internal screw terminals for cable connection and their pin layout is according to the definition given in EN 50170. Also convenient means are usually provided to connect the cable shield to the protective ground. Refer to the Profibus User Organization for more information on availability of these connectors. Profibus Interconnection Technology, Profibus Guideline PNO doc. #2.142.

For the MF.. series with the M12 Profibus connector a special bus terminator must be used. This bus terminator, e.g. TURCK p.n. RSS4.5-PDP-TR, contains het terminator resistors which must be connected to the begin and end of the Profibus cable. To feed the resistors with the VP (+5V) and GND signal it must be connected directly to a T-splitter, e.g. TURCK p.n. RKSWS4.5[5]-2RSSWS, on top of a mass flow device. If a cable is used this cable must contain all five wires and not just only the two red and green wires for the profibus signals.

See the figure below for example of the hook up of an M12 bus terminator to the MF.. series.

Figure 3-7: Recommended TEE and Terminator resistor

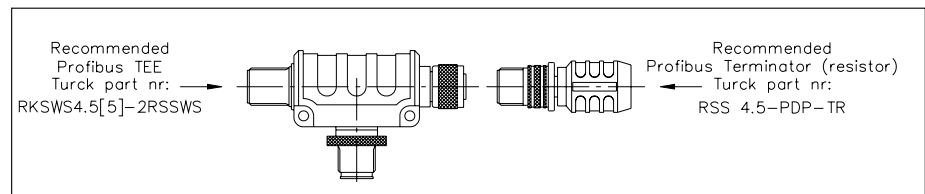

3.6.3 Special requirements for high-speed communication

In case the network is to be operated at baud rates higher then 1.5 Mbaud, the cable length in combination with the capacitive load of the station may generated line reflections, causing interference. This may make communication at these baud rates impossible.

In order to prevent these effects special precautions must be taken. A special connection plug combination is required, including two serially placed inductors each one in each network line. It is recommended that the inductors be placed in the connector rather than in the Profibus device. It is also recommended to place inductors in each line segment starting or ending at any station connector. Therefore stub lines should also not be used, when operating the network at high baud rates.

The value of each inductor is determined to be 120 nH, assuming the total capacity for a bus station of approximately 30pF (taking in to account the capacity of the connector, the line length to the RS-485 driver etc.). Refer to Figure 3-4 below for installation. The before mentioned special Profibus connectors often include the inductors for each cable segment connected to that connector. Ensure that the selected connector is suited for operation at higher baud rates than 1.5 Mbaud.

Figure 3-8: High-speed communication inductors.

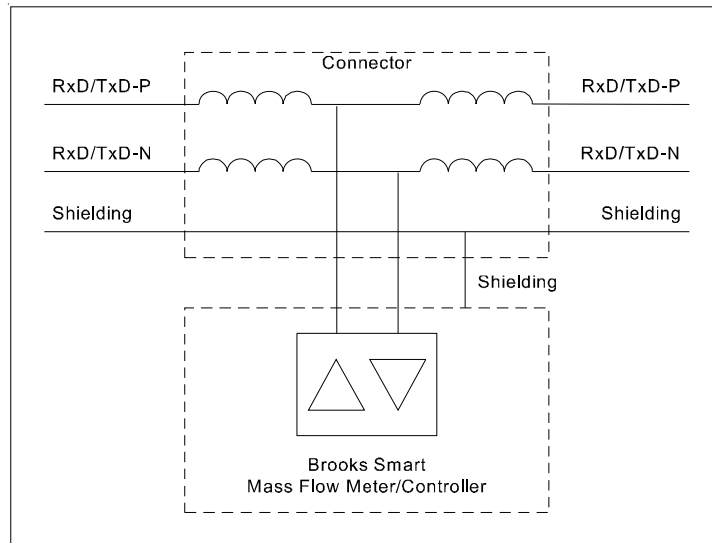

4 Slave configuration

4.1 INTRODUCTION

The purpose of the bus system is the fast serial linkage of the de-central peripherals (Mass Flow Controllers - Meters) with the central Master (controller). In addition to the Input/Output data also parameter data, configuration data and diagnosis data is transferred.

Many Profibus masters (controllers) need a configuration program with which the network structure is described, e.g. SIEMENS STEP7 for the S7 controller. These programs require the unit master file (GSD file). These files can be required from the manufacturer or in case of PNO certified equipment, they can be retrieved from the www.profibus.com web site.

For the Profibus-DP network configuration of the Smart Mass Flow Controllers / Meters slaves the following GSD files are provided:

1. BIMF5801.GSD - Smart Mass Flow Controllers (MFC)
2. BIMF5861.GSD - Smart Mass Flow Meters (MFM)

and can be found on the www.profibus.com web site or requested at your Brooks Sales representative.

4.2 ILLUSTRATION OF THE PROFIBUS-DP COMMUNICATION PROCEDURE

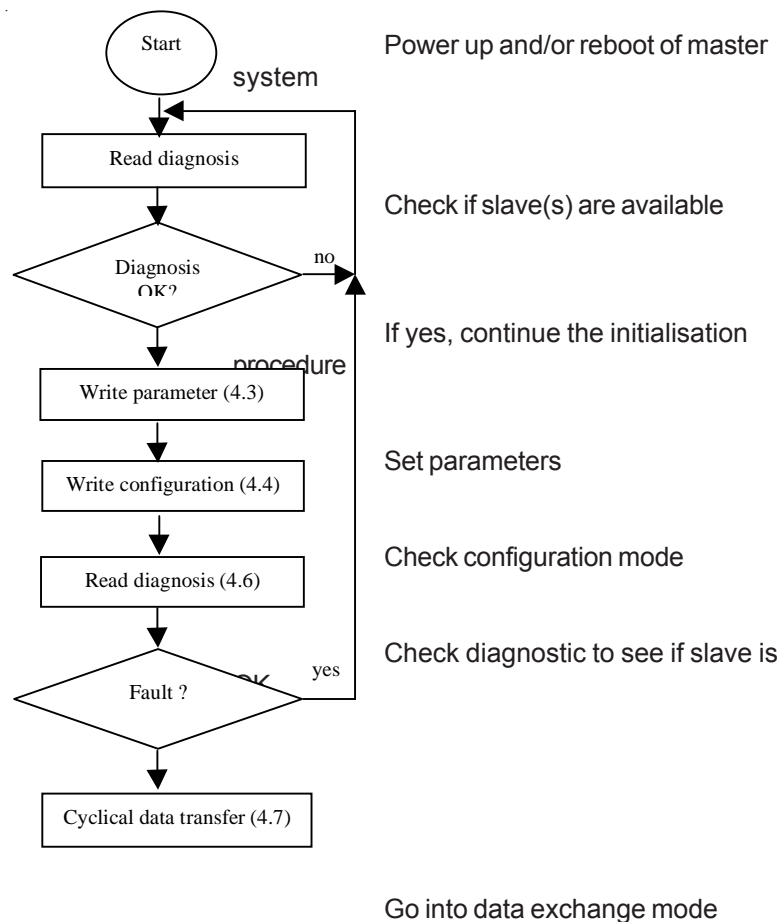

4.3 PARAMETERIZATION OF THE SLAVE (MASS FLOW CONTROLLER)

When the system is running up, each slave receives parameters from the master. The first 7 bytes are defined by the DIN 19245 T3 standard (bus parameters). The following bytes are user parameters (User_Prm_Data). The input of the parameter data takes place in different ways in the various configuration programs (e.g. STEP7). In many cases, the bytes defined by the standard are read from the GSD file.

The user can make the selections as listed in the next section using a configurator program and the files provided. The Brooks Smart Mass Flow Controller is classified as a compact device.

Byte	Mass Flow Controller
1-7	Bus parameters (System parameters)
	User Prm Data (User parameters)
8	Code for SPC3 ASIC
9	Select gas calibration
10	Failsafe state
11	Primary non fatal alarms
12	Secondary non fatal alarms
13	Non fatal ambient alarms
14	Softstart selection
15	Softstart data (%/sec)
16	Flow unit
17	Temperature unit
18	Totalizer unit
19	Setpoint source
20	Adaptive control

Byte	Mass Flow Meter
1-7	Bus parameters (System parameters)
	User Prm Data (User parameters)
8	Code for SPC3 ASIC
9	Select gas calibration
10	reserved
11	Primary non fatal alarms
12	Secondary non fatal alarms
13	Non fatal ambient alarms
14	reserved
15	reserved
16	Flow unit
17	Temperature unit
18	Totalizer unit

The parameters are described more in detail on the next pages.

Installation and Operation Manual

X-DPT-Profibus-Interface-eng

PN 541-C-068-AAG

November, 2008

Mass Flow Controller						
byte #	bit #	type	range [dec]	default [dec]	options	description
8		byte	n.a.	0	Internal system parameter	
					n.a.	reserved
9		byte	1..10	1	Select gas calibration	
					1 = curve 1	Select gas calibration curve
					2 = curve 2	
					3 = curve 3	
					4 = curve 4	
					5 = curve 5	
					6 = curve 6	
					7 = curve 7	
					8 = curve 8	
					9 = curve 9	
10 = curve 10						
10		byte	0..3	1	Failsafe state	
					0 = no effect	Select emergency state if communication is lost
					1 = Valve no power & setpoint = 0.0	
					2 = Valve close & setpoint = 0.0	
3 = Valve open & setpoint = 0.0						
11					Primary non fatal alarms	
	0	bit		1	0 = disabled, 1 = enabled	Flow Sensor Error
	1	bit		1	0 = disabled, 1 = enabled	Temperature Sensor Error
	2	bit		1	0 = disabled, 1 = enabled	Analogue Output Error
	3	bit		1	0 = disabled, 1 = enabled	Setpoint overrange
	4	bit		1	0 = disabled, 1 = enabled	Flow out of range
	5	bit		1	0 = disabled, 1 = enabled	Output out of range
	6	bit		1	0 = disabled, 1 = enabled	Valve out of range
7	bit		0	0	reserved	
12					Secondary non fatal alarms	
	0	bit		0	0 = disabled, 1 = enabled	Low Flow Alarm
	1	bit		0	0 = disabled, 1 = enabled	High Flow Alarm
	2	bit		0	0 = disabled, 1 = enabled	Totalizer overflow
	3	bit		0	0	reserved
	4	bit		0	0	reserved
	5	bit		0	0	reserved
	6	bit		0	0	reserved
7	bit		0	0	reserved	
13					Ambient non fatal alarms	
	0	bit		1	0 = disabled, 1 = enabled	Temperature Too High
	1	bit		1	0 = disabled, 1 = enabled	Power Failure
	2	bit		1	0 = disabled, 1 = enabled	No Flow indication
	3	bit		0	0	reserved
	4	bit		1	0 = disabled, 1 = enabled	Temperature Too Low
	5	bit		1	0 = disabled, 1 = enabled	Flow Obstruction
	6	bit		0	0	reserved
7	bit		0	0	reserved	
14		byte	0..4	0	Select softstart option	
					0 = off	Softstart disabled
					1 = Non-linear	Softstart no-linear
					2 = Linear up	Softstart linear-up only
					3 = Linear down	Softstart linear-down only
4 = Linear up&down	Softstart linear up&down					

15		byte	1...200	100	Select softstart ramp-up and ramp-down speed	
					1...200 = %/s	Percent per second
16		byte	0..24	0	Select flow unit	
					0 = %	Percent of full scale
					1 = ml/sec	Milliliter per second
					2 = ml/min	Milliliter per minute
					3 = ml/hr	Milliliter per hour
					4 = l/sec	Liter per second
					5 = l/min	Liter per minute
					6 = l/hr	Liter per hour
					7 = m3/sec	Cubic metre per second
					8 = m3/min	Cubic metre per minute
					9 = m3/hr	Cubic metre per hour
					10 = ft3/sec	Cubic feet per second
					11 = ft3/min	Cubic feet per minute
					12 = ft3/hr	Cubic feet per hour
					13 =	reserved
					14 =	reserved
					15 =	reserved
					16 = g/sec	Gram per second
					17 = g/min	Gram per hour
					18 = g/hr	Gram per hour
					19 = kg/sec	Kilogram per second
					20 = kg/min	Kilogram per minute
					21 = kg/hr	Kilogram per hour
					22 = Lb/sec	Pound per second
23 = Lb/min	Pound per minute					
24 = Lb/hr	Pound per hour					
17		byte	0..2	1	Select temperature unit	
					0 = Kelvin	Temperature in Kelvin
					1 = Celsius	Temperature in Celsius
					2 = Fahrenheit	Temperature in Fahrenheit
18		byte	0..18	1	Select totalizer unit	
					0 = ml	Milliliter
					1 = Liter	Liter
					2 = m3	Cubic meter
					3 = ft3	Cubic feet
					4 =	reserved
					5 =	reserved
					6 =	reserved
					7 =	reserved
					8 =	reserved
					9 =	reserved
					10 =	reserved
					11 =	reserved
					12 =	reserved
					13 =	reserved
					14 =	reserved
					15 =	reserved
					16 = g	Gram
17 = kg	Kilogram					
18 = Lb	Pounds					
19		byte	1..3	3	Setpoint source selection	
					1 = 0-5 Vdc / 0-20mA	Not for MF.. series
					2 = 1-5 Vdc / 4-20mA	Not for MF.. series
					3 = Profibus	

Installation and Operation Manual

X-DPT-Profibus-Interface-eng

PN 541-C-068-AAG

November, 2008

20		byte	0..2	1	Select adaptive control option	
					0 = Off	
					1 = Tune offset	
					2 = Tune offset & span	
21		byte	n.a.	0	Extended user parameter	
					n.a.	reserved

Mass Flow Meter

byte #	bit #	type	Range [dec]	default [dec]	options	description	
8		byte	n.a.	0	Internal system parameter		
					n.a.	reserved	
9		byte	1..10	1	Select gas calibration		
					1 = curve 1		Select gas calibration curve
					2 = curve 2		
					3 = curve 3		
					4 = curve 4		
					5 = curve 5		
					6 = curve 6		
					7 = curve 7		
					8 = curve 8		
					9 = curve 9		
10 = curve 10							
10		byte	n.a.	0	Not used		
					n.a.	reserved	
11					Primary non fatal alarms		
	0	bit		1	0 = disabled, 1 = enabled	Flow Sensor Error	
	1	bit		1	0 = disabled, 1 = enabled	Temperature Sensor Error	
	2	bit		1	0 = disabled, 1 = enabled	Analogue Output Error	
	3	bit		1	0	reserved	
	4	bit		1	0 = disabled, 1 = enabled	Flow out of range	
	5	bit		1	0 = disabled, 1 = enabled	Output out of range	
	6	bit		1	0	reserved	
	7	bit		0	0	reserved	
12					Secondary non fatal alarms		
	0	bit		0	0 = disabled, 1 = enabled	Low Flow Alarm	
	1	bit		0	0 = disabled, 1 = enabled	High Flow Alarm	
	2	bit		0	0 = disabled, 1 = enabled	Totalizer overflow	
	3	bit		0	0	reserved	
	4	bit		0	0	reserved	
	5	bit		0	0	reserved	
	6	bit		0	0	reserved	
	7	bit		0	0	reserved	
13					Ambient non fatal alarms		
	0	bit		1	0 = disabled, 1 = enabled	Temperature Too High	
	1	bit		1	0 = disabled, 1 = enabled	Power Failure	
	2	bit		0	0	reserved	
	3	bit		0	0	reserved	
	4	bit		1	0 = disabled, 1 = enabled	Temperature Too Low	
	5	bit		0	0	reserved	
	6	bit		0	0	reserved	
	7	bit		0	0	reserved	
14		byte	n.a.	0	Not used		
					n.a.	reserved	

15		byte	n.a.	0	Not used	
					n.a.	reserved
16		byte	0..24	0	Select flow unit	
					0 = %	Percent of full scale
					1 = ml/sec	Milliliter per second
					2 = ml/min	Milliliter per minute
					3 = ml/hr	Milliliter per hour
					4 = l/sec	Liter per second
					5 = l/min	Liter per minute
					6 = l/hr	Liter per hour
					7 = m ³ /sec	Cubic metre per second
					8 = m ³ /min	Cubic metre per minute
					9 = m ³ /hr	Cubic metre per hour
					10 = ft ³ /sec	Cubic feet per second
					11 = ft ³ /min	Cubic feet per minute
					12 = ft ³ /hr	Cubic feet per hour
					13 =	reserved
					14 =	reserved
					15 =	reserved
					16 = g/sec	Gram per second
					17 = g/min	Gram per hour
					18 = g/hr	Gram per hour
					19 = kg/sec	Kilogram per second
					20 = kg/min	Kilogram per minute
					21 = kg/hr	Kilogram per hour
					22 = Lb/sec	Pound per second
23 = Lb/min	Pound per minute					
24 = Lb/hr	Pound per hour					
17		byte	0..2	1	Select temperature unit	
					0 = Kelvin	Temperature in Kelvin
					1 = Celsius	Temperature in Celsius
					2 = Fahrenheit	Temperature in Fahrenheit
18		byte	0..18	1	Select totalizer unit	
					0 = ml	Milliliter
					1 = Liter	Liter
					2 = m ³	Cubic meter
					3 = ft ³	Cubic feet
					4 =	reserved
					5 =	reserved
					6 =	reserved
					7 =	reserved
					8 =	reserved
					9 =	reserved
					10 =	reserved
					11 =	reserved
					12 =	reserved
					13 =	reserved
					14 =	reserved
					15 =	reserved
					16 = g	Gram
17 = kg	Kilogram					
18 = Lb	Pounds					

Using the configurator and with the selected device, "S-series MFC", the parameters can be viewed in the configuration tool and adjusted against the customer configuration of the device.

Installation and Operation Manual

X-DPT-Profibus-Interface-eng

PN 541-C-068-AAG

November, 2008

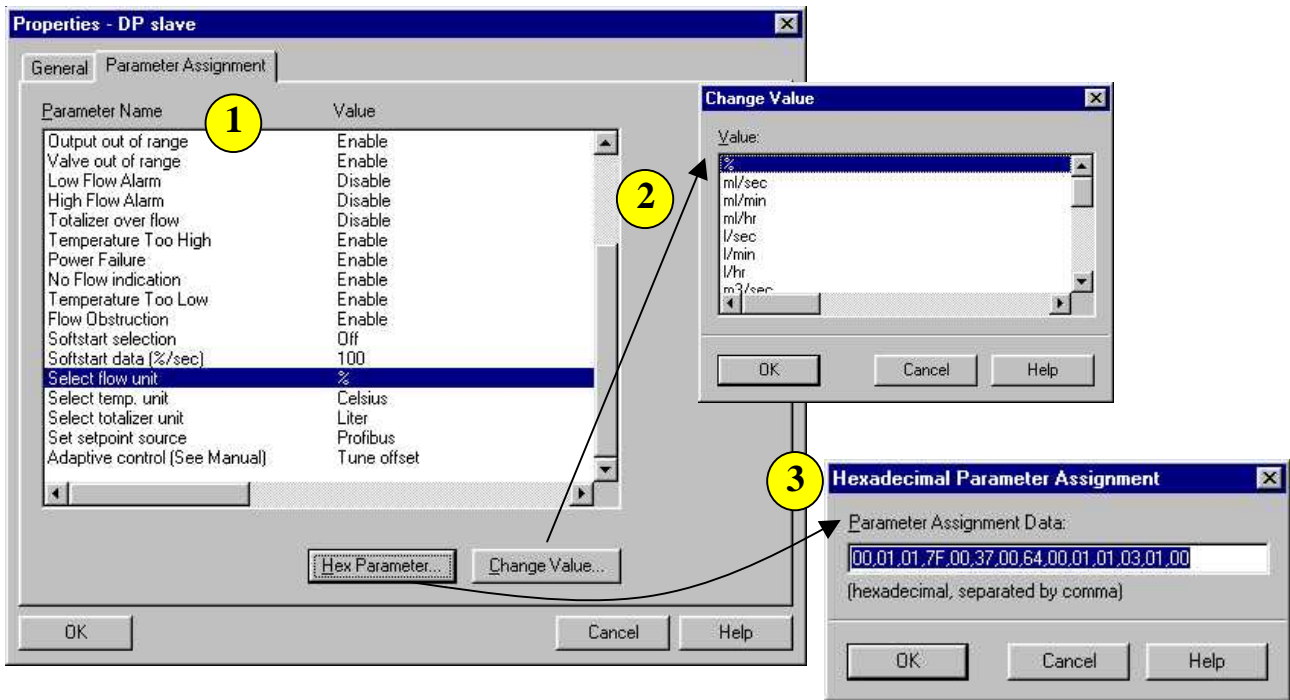

Using the STEP 7 configurator from Siemens one will see the slaves in the *hardware configuration* and by double clicking on these slaves the window properties of the slave is opened. In case of the selecting the Parameter Assignment tab the above window is shown [1]. Here the parameters are shown by name and their value. This information is imported from the GSD file. The parameter setting can be changed by selecting one of the parameter names and opening the Change Value window by entering the Change Value button [2]. Now all possible options are shown and a new option can be chosen. All parameters will be sent to the slave by the parameterization message. The hexa decimal value of this can directly be seen, or changed, via the Hexadecimal Parameter window [3].

4.4 CONFIGURATION OF THE SLAVE

With the configuration telegram, the number of input and output bytes for the data exchange mode is compared. The entry takes place via identifier bytes. A configuration telegram can contain one or more identifiers. In case of the Brooks Mass Flow products the special identifier format is used. This first code indicates one byte of output data length follows, one byte of input data length follows and one byte of manufacturer specific data. The latter is the module number which is known to the Brooks DP slave.

The Mass Flow Controller is making use of the special identifier byte after which one of the three I/O configuration possibilities can be sent.

For module 1:

Byte	Code	Description
1	0xC1	Special identifier with one length byte each for Output and Input follows, with one byte of vendor specific data
2	0x83	Output data, 4 bytes (1 float)
3	0x83	Input data, 4 bytes (1 float)
4	0x01	Manufacturer specific data, module #1

For module 2:

Byte	Code	Description
1	0xC1	Special identifier with one length byte each for Output and Input follows, with one byte of vendor specific data
2	0x84	Output data, 5 bytes (1 float + 1 byte)
3	0x88	Input data, 9 bytes (2 floats + 1 byte)
4	0x02	Manufacturer specific data, module #2

For module 3:

Byte	Code	Description
1	0xC1	Special identifier with one length byte each for Output and Input follows, with one byte of vendor specific data
2	0x84	Output data, 5 bytes (1 float + 1 byte)
3	0x94	Input data, 21 bytes (4 floats + 1 unsigned integer + 1 byte)
4	0x03	Manufacturer specific data, module #3

The Mass Flow Meter is also making use of the special identifier byte after which one of the two I/O configuration possibilities can be sent.

For module 1:

Byte	Code	Description
1	0x41	Special identifier with one byte length Input follows, with one byte of vendor specific data
2	0x83	Input data, 4 bytes (1 float)
3	0x01	Manufacturer specific data, module #1

For module 2:

Byte	Code	Description
1	0xC1	Special identifier with one length byte each for Output and Input follows, with one byte of vendor specific data
2	0x80	Output data, 1 byte
3	0x8C	Input data, 13 bytes (3 floats + 1 byte)
4	0x02	Manufacturer specific data, module #2

In case of a configuration tool, e.g. STEP7, see the example below.

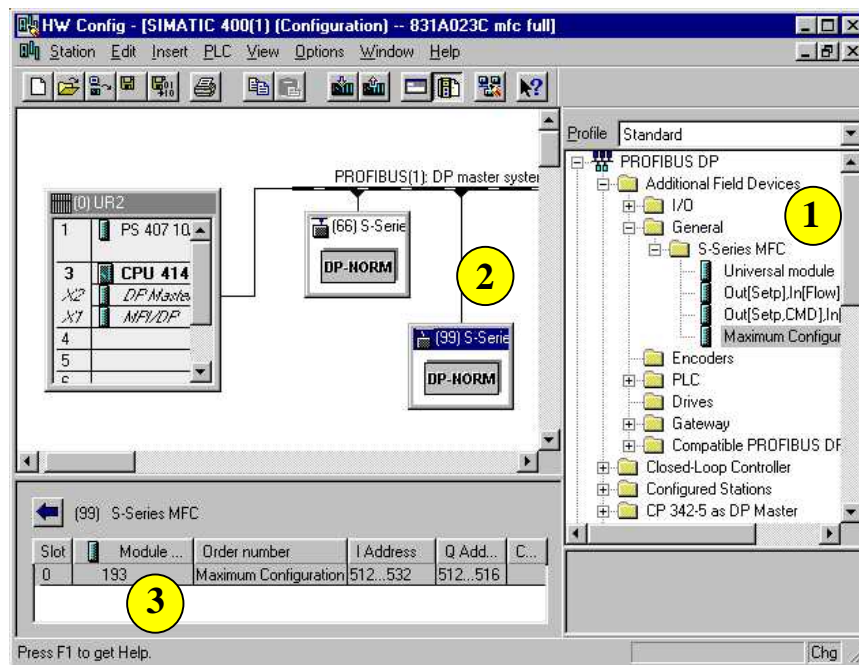

Using STEP7, one can make a selection from one of the modules that are declared in the GSD file. When selecting the slave type from the configuration tool, see [1], this folder can be picked up and dragged into the PROFIBUS DP master system rail [2]. The next step is to select one of the modules [1]. Here the 'maximum configuration' is picked up and dragged into the slave module slot [3]. Now the slave configuration is done and can be saved, compiled downloaded into the S7 controller.

4.5 DIAGNOSTIC

4.5.1 Device diagnostic Message

Any Smart TMF series device features extensive diagnostics capabilities. Access to this information is provided through the Profibus-DP defined diagnostics message. In the start-up state, when connected to the network and prior to entering the data exchange state, the device will generate two diagnostic messages: one right after power up to notify the master of its presence on the network, and one after successful configuration check, to notify the master that the system is ready for regular data exchange.

A device diagnostics message send by a Smart TMF series device will at least contain the 6 bytes of mandatory diagnostics as defined by the standard. Refer to EN 50170, part 3, section 8.3.1.: *Read DP-slave diagnostic information* for a detailed description of these first 6 bytes. If the device has no error or alarm to report, no further extended diagnostic bytes are send to the master. The mere absence of extended diagnostics information indicates “No errors to report”, thus limiting the burden on the network to a minimum.

In case if one of the errors occurs (or changes), a complete diagnostics message, including also the bytes indicating the other categories will send to the master after the next data exchange message.

Table 5-1 below summarizes the diagnostic data bytes to be send at the event of an error (change). If all bits in all bytes are 0, these data bytes will not be send. A short message indicates “no errors”. The data bytes are send left to right, i.e. byte 0 is send first.

Table 5-1: Diagnostics message, extended data section layout.

Diagnostics message – Extended data section*				
Byte 0	Byte 1	Byte 2	Byte 3	Byte 4
Run-time message errors	Fatal system errors	Primary non-fatal system errors	Secondary non-fatal system errors	Non-fatal ambient errors

* These bytes are only send if one of the bits is set to 1.

Each of the error/alarm bytes is explained in the next sections.

4.5.2 Run-time message errors

Table 5-2 below shows the bit-mapped alarm bits of the first extended diagnostics byte, the Run-time message errors. These error bits are used to notify the master, that one (or more) of the command settings, has been ignored for some reason. The errors are non-fatal, i.e. the device will continue to function as before, but the command involved is ignored. Refer also to section 4.6 for an explanation of the valid command byte selection codes.

Table 5-2: Diagnostics: Run-time message error bits.

Diagnostics byte 0: Run-time message errors							
Bit 7	Bit 6	Bit 5	Bit 4	Bit 3	Bit 2	Bit 1*	Bit 0
Reserved				Device busy command ignored	Invalid totalizer command	Invalid VOR command	Invalid EEPROM command
0	0	0	0	0=OK 1=Alarm	0=OK 1=Alarm	0=OK 1=Alarm	0=OK 1=Alarm

* This error will also be set if the slave device is a meter model, and a non-zero valve override command is given.

Explanation of error bits:

1. **Invalid EEPROM command:** The code send to the slave device with command byte 1 is invalid. i.e. the two least significant bits of the first command byte have both been set to 1.
2. **Invalid VOR command:** The valve override command code send to the slave device with command byte 2 is invalid. Either a number ranging from 6 to 15 has been set in the lower nibble, which is not allowed for a Smart TMF controller model, or a non-zero number has been set and the addressed device is a Smart TMF meter model. The command has been ignored.
3. **Invalid totalizer command:** The totalizer command code send to the slave device with command byte 2 is invalid, i.e. a number ranging from 3 to 15 has been set in the higher nibble. The command has been ignored.
4. **Device busy, command ignored:** Either a zero command code or an EEPROM command code has been send to the device, which is however still processing the previous zero or EEPROM command. The command has been ignored.

4.5.3 Fatal system errors

Table 5-3 below shows the bit-mapped alarm bits of the second extended diagnostics byte, the fatal system errors. These error bits all indicate a fatal system alarm, prevent the device from correct operation. The occurrence of one of these fatal alarms will cause a system shutdown. Also in the diagnostics message the static diagnostics bit will be set, i.e. the diagnostics message is the only message to be send by the device. These alarm situations will not disappear by them selves and immediate service is required.

Table 5-3: Diagnostics: Fatal system error bits

Diagnostics byte 1: Fatal system errors							
Bit 7	Bit 6	Bit 5	Bit 4	Bit 3	Bit 2	Bit 1	Bit 0
Reserved			Sensor zero error	EEPROM error	Database error	SRAM R/W error	EPROM error
0	0	0 1=Alarm	0=OK 1=Alarm	0=OK 1=Alarm	0=OK 1=Alarm	0=OK 1=Alarm	0=OK

Explanation of error bits:

1. **EPROM error:** At start-up (after system reset or power up) the system EPROM, containing the program is checked by determining the checksum. If a checksum error has been detected, the system is shut down. If communication is achieved, this bit will be set in the second diagnostics byte. The error can not be masked.
2. **SRAM R/W error:** At start-up (after system reset or power up) the performance of the system SRAM is checked by writing and reading specific test patterns at all locations. If a faulty location has been found, the system is shutdown. If communication is achieved, this bit will be set in the second diagnostics byte. The error can not be masked.
3. **Database error:** At start-up (after system reset or power up) and continuously during operation the parameter database is checked by checking each parameter's checksum. If a mismatch is found between the calculated checksum and the stored checksum at a certain parameter location, the database is considered to have become invalid. Bit 2 will be set in the second diagnostics byte, and the system is shutdown. The error can not be masked.

4. EEPROM error: During operation the backup parameter database, located in EEPROM is continuously checked by comparing the contents of each parameter in the operational database (including the checksum) with the contents of the backup database. If a mismatch is found between two parameter values, the backup database is considered to have become invalid. Bit 3 will be set in the second diagnostics byte, and the system is shutdown. The error can not be masked.

5. Sensor zero error: If after a sensor zero command the processor has been unable to achieve a residual sensor zero signal of less than 5%, the flow sensor measurement accuracy can no longer be guaranteed. Bit 4 will be set in the second diagnostics byte, and the system is shutdown. The error can not be masked.

4.5.4 Primary non-fatal system errors

Table 5-4 below shows the bit-mapped alarm bits of the third extended diagnostics byte, the primary non-fatal system errors. These error bits all indicate a primary (i.e. system hardware related) non-fatal system alarm. At the occurrence of one or more of these alarms the device will continue to operate as best as possible. Erroneous signal levels are limited to operational levels before processing and the alarm will disappear if the situation returns to normal. All of these error/alarm message bits can be disabled through the parameterization message.

Table 5-4: Diagnostics: Primary non-fatal system error/alarm bits.

Diagnostics byte 2: Primary non-fatal system errors/alarms							
Bit 7	Bit 6 *	Bit 5	Bit 4	Bit 3 *	Bit 2	Bit 1	Bit 0
Reserved	Valve out of range	Analogue output error	Flow sensor of range	Setpoint over range	Analogue output out of range	Temp. sensor error	Flow sensor error
0	0=OK 1=Alarm	0=OK 1=Alarm	0=OK 1=Alarm	0=OK 1=Alarm	0=OK 1=Alarm	0=OK 1=Alarm	0=OK 1=Alarm

* Applies to controller models only. For meter models these bits will never be set.

Explanation of error/alarm bits:

- 1. Flow sensor error:** This error occurs if the sensor signal level drops below a minimum level. This may result from a disconnected sensor, but also from reversed flow.
- 2. Temperature sensor error:** This error occurs if the sensor signal level drops below a minimum level. This may result from a disconnected sensor.
- 3. Analogue output error:** The analogue output error is generated if the analogue output signal level differs more than 10% from the expected level. It may result from defective electronics.
- 4. Setpoint overrange:** The setpoint overrange alarm is set if the setpoint signal, either analogue or through the network exceeds 105%. The setpoint used in processing is limited to 105%.
- 5. Flow sensor out of range:** This error occurs if the sensor signal exceeds the maximum physical signal level. The sensor signal level is limited to this maximum before processing.
- 6. Analogue output out of range:** This error occurs if the analogue output signal to be set exceeds the maximum physical signal level allowed with the electronics. The analogue output level set is the maximum physical value achievable with the electronics.
- 7. Valve out of range:** This error occurs if the control value set on the valve has reached the maximum possible level. The actual value set is limited to the maximum value allowed. This error may result from a situation where there is no gas supplied and yet a setpoint exceeding 0% is present.

4.5.5 Secondary non-fatal system errors

Table 5-5 below shows the bit-mapped alarm bits of the fourth extended diagnostics byte, the secondary non-fatal system errors. These error bits all indicate a secondary non-fatal system alarm, non-hardware related. At the occurrence of one or more of these alarms the device will continue to operate as best as possible. Again erroneous signal levels are limited to operational levels before processing and the alarm will disappear if the situation returns to normal. All of these error/alarm message bits can be disabled through the parameterization message.

Table 5-5: Diagnostics: Secondary non-fatal system error/alarm bits.

Diagnostics byte 3: Secondary non-fatal system errors/alarms							
Bit 7	Bit 6	Bit 5	Bit 4	Bit 3	Bit 2	Bit 1	Bit 0
Reserved					Totalizer overflow	High flow error	Low flow error
0	0	0	0	0	0=OK 1=Alarm	0=OK 1=Alarm	0=OK 1=Alarm

Explanation of error/alarm bits:

1. **Low flow error:** This error occurs if the flow signal drops below the low flow alarm limit, set in the database. The alarm will disappear if the signal exceeds the low flow limit again.
2. **High flow error:** This error occurs if the flow signal exceeds the high flow alarm limit, set in the database. The alarm will disappear if the signal drops below the high flow limit again.
3. **Totalizer overflow:** The totalizer overflow error occurs if the maximum value of the totalizer is reached. The totalizer will roll over and start again from 0, but the overflow is signalled to the master. It will only disappear after a totalizer reset.

4.5.6 Non-fatal ambient errors

Finally Table 5-6 below shows the bit-mapped alarm bits of the fifth extended diagnostics byte, the non-fatal ambient errors. These error bits all indicate an ambient related non-fatal ambient related alarm. At the occurrence of one or more of these alarms the device will continue to operate as best as possible. Again erroneous signal levels are limited to operational levels before processing and the alarm will disappear if the situation returns to normal. All of these error/ alarm message bits can be disabled through the parameterization message.

Table 5-6: Diagnostics: Non-fatal ambient error/alarm bits.

Diagnostics byte 4: Non-fatal ambient errors/alarms							
Bit 7	Bit 6	Bit 5 *	Bit 4	Bit 3	Bit 2 *	Bit 1	Bit 0
Reserved		Flow obstruct. error	Temp. too low error	Reserved	No flow indication error	Power too low error	Temp. too high error
0	0	0=OK 1=Alarm	0=Ok 1=Alarm	0	0=OK 1=Alarm	0=OK 1=Alarm	0=OK 1=Alarm

* Applies to controller models only. For meter models these bits will never be set.

Explanation of error/alarm bits:

1. **Temperature too high error:** If the ambient temperature exceeds the device's maximum operating temperature, this alarm will be set. It will disappear if the temperature drops below the maximum operating temperature again.
2. **Power too low error:** The power too low error bit is set if the internal analogue power level drops below 12 Vdc. The digital level can still operate, but the analogue read-out can become inaccurate. This may be caused by a short-circuit on board the electronics.
3. **No flow indication error:** This error may occur if the valve out of range alarm is also set. It indicates the absence of flow, although the valve is fully opened. It may be caused by a lack of gas supply. This alarm does not occur if the device is a meter model, and it disappears if the gas flow returns to normal.
4. **Temperature too low error:** If the ambient temperature drops below the device's minimum operating temperature, this alarm will be set. It will disappear if the temperature exceeds the minimum operating temperature again.
5. **Flow obstruction error:** This error may occur if the valve out of range alarm is also set. It indicates a possible obstruction of gas flow, although the valve is fully opened. This may be due to a partially block gas supply or outlet (i.e. the gas is not fully zero). This alarm does not occur if the device is a meter model, and it disappears if the gas flow returns to normal.

4.6 DATA EXCHANGE MODE

This function permits the local user of the DP-Master to transmit output data to a DP-Slave and at the same time to request input data from this remote station. The number of input and output data which are reserved by the DP-Slave are checked against the configuration data during the start-up phase of the DP-System (see the chapter 4.5 Configuration).

The data exchange mode will remain until the master is stopped or the network is reconfigured. The set of actual parameters is selected during the configuration of the slave. For the controller model there are three modules of input / output available and two modules for the meter model. On the following page tables are shown with the memory map (order parameters) of these modules. Please, make also notice of the notes concerning the command byte and the consistent data construction at the end of this paper.

I/O memory map MFC, Mass Flow Controller bimf5801.gsd				
module 1: "out[Setp],in[Flow]"				
Output	description	byte #	byte size	type
Setp	setpoint	0.....3	4	floating point
Input	description	byte #	byte size	type
Flow	flow	0.....3	4	floating point

I/O memory map Mass Flow Controller bimf5801.gsd				
module 2: "out[Setp,CMD],in[Flow,Tot,CMD]"				
Output	description	byte #	byte size	type
Setp	setpoint	0.....3	4	floating point
CMD	command	4.....7	1	unsigned byte
Input	description	byte #	byte size	type
Flow	flow	0.....3	4	floating point
Tot	totalizer	4.....7	4	floating point
CMD	command	8	1	unsigned byte

I/O memory map Mass Flow Controller bimf5801.gsd				
module 3: "Maximum Configuration"				
Output	description	byte #	byte size	type
Setp	setpoint	0.....3	4	floating point
CMD	command	4	1	unsigned byte
Input	description	byte #	byte size	type
Setp	actual setpoint of the MFC	0.....3	4	floating point
Flow	flow	4.....7	4	floating point
Temp	temperature	8...11	4	floating point
Tot	totalizer	12..15	4	floating point
Valv	valve drive indicator	16..19	4	unsigned integer
CMD	command	20	1	unsigned byte

I/O memory map Mass Flow Meter bimf5861.gsd				
module 1: "out[-],in[Flow]"				
Output	description	byte #	byte size	type
-	-	-	-	-
Input	description	byte #	byte size	type
Flow	flow	0.....3	4	floating point

I/O memory map Mass Flow Meter bimf5861.gsd				
module 2: "out[CMD],in[Flow,Temp,Tot,CMD]"				
Output	description	byte #	byte size	type
CMD	command	0	1	unsigned byte
Input	description	byte #	byte size	type
Flow	flow	0.....3	4	floating point
Temp	temperarure	4.....7	4	floating point
Tot	totalizer	8...11	4	floating point
CMD	command	12	1	unsigned byte

In the memory map of the MFC and MFM are mainly actual variables for e.g. flow, setpoint and so on. One special case here is the CMD or command byte. Through this byte there is the possibility to control the totalizer and Valve Override functions. Using the output the function is sent to the MFC or MFM while the internal command status can be read back via the input data.

In the following table the functionality of this command byte is shown. Although it is one byte with two functions, totalizer and valve override, this byte is representing two nibbles (4 bits):

- Low order nibble provides the command 'Valve override'.
- High order nibble provides the command 'Totalizer'.

Function: CMD				
type	bit #	range [dec]	default [dec]	options
nibble, low order 4-bits of byte	0..3	0..5	0	Valve Override command
				0 = Valve Override Off
				1 = Valve Open
				2 = Valve Close
				3 = Valve No Power
				4 = Valve Full Power
nibble, high order 4-bits of byte	4..7	0..2	0	Totalizer command
				0 = Stop totalizer
				1 = Run totalizer
				2 = Reset totalizer

Note 1

The readback of a CMD is representing the internal status of the MFC / MFM which in case of an external analogue VOR command and totalizer reset are not identical as has been sent via the output data byte. In case of the totalizer is running and is reset by the output data byte the status is not showing the reset status but still falls back in the running mode. However this will be overruled by the constant stream of output bytes.

In a table this is looking as:

Input CMD byte	Output CMD byte	totalizer value
1x	1x	1234.56
1x	2x	0.0

(x = don't care, can be any value)

Note 2

The totalizer value is not accumulating anymore in case of a 'valve out of range' alarm or Valve Override Open is generated. In such case the flow value can be out of range and not reliable to the totalizer.

Note 3

In case of the valve override function the input command byte is representing the same value as been sent via the output data byte, except if the analogue valve override input is used. This analogue input has a higher priority above the valve override command through the profibus. This is done for safety reasons. So, in this case the input command data is representing the **actual** valve override status.

Note 4

For all module types the input and output data are defined as consistent data, meaning that the input or output data stream belongs together and cannot be split in separate partitions. When using PLC programming software, in most cases this must be split up by special routines, toherwise this could result in corrupt and useless data, which can lead to undefined situations.

Example:

When a DP-slave operates in module 'out[Setp], in[Flow]', the input and output stream is only 4 bytes long. Because Siemens S7-300 and S7-400 hardware are internally 32-bit architectures, you can access the data direct by using keywords PID and PQD. But in case the DP-slave operates in module type 2 or 3, the data stream is always larger than 4 bytes. This means that you must use special software routines, supplied by the manufacturer, e.g. Siemens, to read or write data from or to the slave device.

For STEP7 (Siemens) the following routines can be used:
SFC14, DPRD_DAT, read consistent data of a standard DP slave.
SFC15, DPRW_DAT, write consistent data to a standard DP slave.
Please, consult the manufacturer of your master device for all detailed information about consistent data exchange.

4.7 EXAMPLE OF THE PROFIBUS-DP COMMUNICATION PROCEDURE

We have just seen the description of the PROFIBUS-DP communication procedure separate Now, by showing a bus trace of the communication procedure of one MFC slave the just described items will be recognised.

The left screenshot shows the 'Recorder' window of the PROFIBUS Analyzer. It displays a list of communication events. The event at line 2.62 is highlighted in blue: '2.62 -> 66.60 DP req. Slave Diag'. Other events include '66.60 -> 2.62 DP res. Slave Diag', '66.61 DP req. Set Parameter', '66.62 DP req. Check Config', and several 'DP req. Data Exchange' events.

The right screenshot shows the 'Hex' view of the selected event. The data is displayed in hexadecimal format. The first line (000106) is highlighted in blue and shows a request for diagnostics: '000106 16:07:44,781329 0 68 05 05 68 c2 82 6d 3c 3e 2b 16'. The next line (000107) shows a response with five zeros: '000107 16:07:44,795084 0 68 11 11 68 82 c2 08 3e 3c 02 05 00 ef 58 01 06 00 00 00 00 00 2b 16'. The following lines (000110, 000114, 000118, 000119) show 'Set Parameter', 'Check Config', and 'Data Exchange' messages. The final lines (000122-000147) show a series of 'Data Exchange' messages.

1. From top, line no. 91, until the selected blue line, line no. 106, the master (Source Address (SA) 2) requests for diagnostics of a slave (Destination Address (DA) 66) but no response is given.
2. At line no. 107 the slave is reacting with the diagnostic message, including the 5 manufacturing specific bytes. In this case all bytes are 00, which indicates no alarm sources are active.
3. First is sent the Set Parameter message, line no. 110. The parameters as described in the parameterisation message can be recognized here, see the underlined data.
4. Next is the Check Configuration message, line no. 114. Here we can recognise the module 3 selection of an MFC.
5. And before going into the data exchange mode, first a diagnostic message is sent to check if the unit is still OK. On line no. 119 the unit here response with 'all OK'.
6. And finally the unit is in data exchange mode, starting from line 122. On line 138 we can recognize the 5 output bytes of which the first 4 are the floating point value of 35 (See also appendix B for more info on the floating point value).
Next line is showing the 21 input bytes.
The data exchange mode is ongoing and will remain exchanging input and output data as long the master is running.

5 Modellisting Model 58.. Series

BROOKS SMART MASS FLOW PRODUCTS	
SMART MASS FLOW METERS / CONTROLLERS	
BASE MODEL NUMBER	DESCRIPTION
5860S/BA	MASS FLOW METER; F.S. FLOWRANGES: 0.003 - 0.008 l/min.
5860S/BC	MASS FLOW METER; F.S. FLOWRANGES: 0.008 - 30 l/min.
5861S/BD	MASS FLOW METER; F.S. FLOWRANGES: 20 - 100 l/min.
5863S/BE	MASS FLOW METER; F.S. FLOWRANGES: 100 - 200 l/min.
5863S/BF	MASS FLOW METER; F.S. FLOWRANGES: 200 - 300 l/min.
5863S/BG	MASS FLOW METER; F.S. FLOWRANGES: 300 - 400 l/min.
5863S/BH	MASS FLOW METER; F.S. FLOWRANGES: 400 - 500 l/min.
5863S/BJ	MASS FLOW METER; F.S. FLOWRANGES: 500 - 600 l/min.
5863S/BK	MASS FLOW METER; F.S. FLOWRANGES: 600 - 700 l/min.
5863S/BL	MASS FLOW METER; F.S. FLOWRANGES: 700 - 800 l/min.
5863S/BM	MASS FLOW METER; F.S. FLOWRANGES: 800 - 900 l/min.
5863S/BN	MASS FLOW METER; F.S. FLOWRANGES: 900 - 1000 l/min.
5863S/B1	MASS FLOW METER; F.S. FLOWRANGES: 1001 - 1100 l/min.
5863S/B2	MASS FLOW METER; F.S. FLOWRANGES: 1101 - 1300 l/min.
5863S/B3	MASS FLOW METER; F.S. FLOWRANGES: 1301 - 1600 l/min.
5863S/B4	MASS FLOW METER; F.S. FLOWRANGES: 1601 - 1900 l/min.
5863S/B5	MASS FLOW METER; F.S. FLOWRANGES: 1 901 - 2200 l/min.
5863S/B6	MASS FLOW METER; F.S. FLOWRANGES: 2201 - 2500 l/min.
5850S/BA	MASS FLOW CONTROLLER; F.S. FLOWRANGES: 0.003 - 0.008 l/min.
5850S/BC	MASS FLOW CONTROLLER; F.S. FLOWRANGES: 0.008 - 30 l/min.
5851S/BD	MASS FLOW CONTROLLER; F.S. FLOWRANGES: 20 - 100 l/min.
5853S/BE	MASS FLOW CONTROLLER; F.S. FLOWRANGES: 100 - 200 l/min.
5853S/BF	MASS FLOW CONTROLLER; F.S. FLOWRANGES: 200 - 300 l/min.
5853S/BG	MASS FLOW CONTROLLER; F.S. FLOWRANGES: 300 - 400 l/min.
5853S/BH	MASS FLOW CONTROLLER; F.S. FLOWRANGES: 400 - 500 l/min.
5853S/BJ	MASS FLOW CONTROLLER; F.S. FLOWRANGES: 500 - 600 l/min.
5853S/BK	MASS FLOW CONTROLLER; F.S. FLOWRANGES: 600 - 700 l/min.
5853S/BL	MASS FLOW CONTROLLER; F.S. FLOWRANGES: 700 - 800 l/min.
5853S/BM	MASS FLOW CONTROLLER; F.S. FLOWRANGES: 800 - 900 l/min.
5853S/BN	MASS FLOW CONTROLLER; F.S. FLOWRANGES: 900 - 1000 l/min.
5853S/B1	MASS FLOW CONTROLLER; F.S. FLOWRANGES: 1001 - 1100 l/min.
5853S/B2	MASS FLOW CONTROLLER; F.S. FLOWRANGES: 1101 - 1300 l/min.
5853S/B3	MASS FLOW CONTROLLER; F.S. FLOWRANGES: 1301 - 1600 l/min.
5853S/B4	MASS FLOW CONTROLLER; F.S. FLOWRANGES: 1601 - 1900 l/min.
5853S/B5	MASS FLOW CONTROLLER; F.S. FLOWRANGES: 1 901 - 2200 l/min.
5853S/B6	MASS FLOW CONTROLLER; F.S. FLOWRANGES: 2201 - 2500 l/min.
MECHANICAL CONNECTIONS	
1A	WITHOUT ADAPTORS (9/16"-18" UNF) (ONLY FOR 5850/60/51/61/53/63)
1B	1/4" TUBE COMPRESSION FITTINGS (ONLY FOR 5850/60/51/61)
1C	1/8" TUBE COMPRESSION FITTINGS (ONLY FOR 5850/60/51/61)
1D	3/8" TUBE COMPRESSION FITTINGS (ONLY FOR 5851/61)
1E	1/4" VCR (ONLY FOR 5850/60/51/61)
1F	1/4" VCO (ONLY FOR 5850/60/51/61)
1G	1/4" NPT (ONLY FOR 5850/60/51/61)
1H	6mm TUBE COMPRESSION FITTINGS (ONLY FOR 5850/60/51/61)
1J	10mm TUBE COMPRESSION FITTINGS (ONLY FOR 5850/60/51/61)
1K	1/4" BSP (F) (ONLY FOR 5850/60/51/61)
1Y	1/2" BSP (F) (ONLY FOR 5853/63)
1Z	1" BSP (F) (ONLY FOR 5853/63)

2A		1 1/16" - 12SAE/MS	(ONLY FOR 5853/63)
2B		1/2" TUBE COMPRESSION FITTINGS	(ONLY FOR 5850/60/51/61/53/63)
2C		3/4" TUBE COMPRESSION FITTINGS	(ONLY FOR 5853/63)
2D		1" TUBE COMPRESSION FITTINGS	(ONLY FOR 5853/63)
2E		1/2" NPT(F)	(ONLY FOR 5853/63)
2F		1" NPT(F)	(ONLY FOR 5853/63)
2G		1 1/2" NPT(F) (SEE OPTION "E")	(ONLY FOR 5853/63/64)
2H		1/2" VCO (200 ln/min. max.)	(ONLY FOR 5850/60/51/61/53/63)
2J		3/4" VCO	(ONLY FOR 5853/63)
2K		1/2" VCR (200 ln/min. max.)	(ONLY FOR 5850/60/51/61/53/63)

BROOKS SMART MASS FLOW PRODUCTS
SMART MASS FLOW METERS / CONTROLLERS

BASE MODEL NUMBER		DESCRIPTION
MECHANICAL CONNECTIONS		
2L		DIN DN15PN40 (ONLY FOR 5853/63)
2M		DIN DN25PN40 (ONLY FOR 5853/63)
2N		DIN DN40PN40 (ONLY FOR 5853/63)
2O		DIN DN50PN40 (ONLY FOR 5853/63)
2P		ANSI 1/2" 150 LBS (ONLY FOR 5853/63)
2R		ANSI 1/2" 300 LBS (ONLY FOR 5853/63)
2S		ANSI 1" 150 LBS (ONLY FOR 5853/63)
2T		ANSI 1" 300 LBS (ONLY FOR 5853/63)
2U		ANSI 1 1/2" 150 LBS (ONLY FOR 5853/63)
2V		ANSI 1 1/2" 300 LBS (ONLY FOR 5853/63)
2W		ANSI 2" 150 LBS (ONLY FOR 5853/63)
2X		ANSI 2" 300 LBS (ONLY FOR 5853/63)
2Y		1" VCO (ONLY FOR 5853/63)
2Z		3/4" VCR (ONLY FOR 5853/63)
9Z		SPECIFY
O-RING/VALVE SEAT MATERIAL		
A		VITON
B		BUNA (NOT FOR 5853)
C		PTFE/KALREZ (KALREZ FOR SENSOR O-RINGS AND VALVE SEAT)
D		KALREZ (NOT FOR 5853)
E		PTFE O-RINGS / EPDM VALVE SEAT
M		KALREZ O-RINGS / METAL VALVE SEAT
Z		SPECIFY
VALVE TYPE		
0		METER ONLY (NO VALVE)
1		NORMALLY CLOSED (5850/51 SERIES)
2		NORMALLY CLOSED (PRESS.DIFF. >2BAR. 5853 SERIES)
3		NORMALLY CLOSED (PRESS.DIFF. <2BAR. 5853 SERIES)
4		NORMALLY OPENED (5850 ONLY)
5		NORMALLY CLOSED, 5850 SERIES, 300 BAR
9		SPECIFY

Installation and Operation Manual

X-DPT-Profibus-Interface-eng

PN 541-C-068-AAG

November, 2008

BROOKS SMART MASS FLOW PRODUCTS		
SMART MASS FLOW METERS / CONTROLLERS		
BASE MODEL NUMBER		DESCRIPTION
ELECTRICAL INPUT/OUTPUT		
		INPUT OUTPUT
A		0-5Vdc 0-5 Vdc & 0-20mA (INCL. RS 232, 9600 BDS)
B		4-20mA 4-20 mA & 1-5Vdc (INCL. RS 232, 9600 BDS)
C		0-20 mA 0-20mA & 0-5Vdc (INCL. RS 232, 9600 BDS)
D		1-5Vdc 1-5 Vdc & 4-20mA (INCL. RS 232, 9600 BDS)
E		DIG. COMM. DIG. COMM. + 0 - 5 Vdc
F		DIG. COMM. DIG. COMM. + 4 - 20 mA
G		DIG. COMM. DIG. COMM. + 0 - 20 mA
H		DIG. COMM. DIG. COMM. + 1 - 5 Vdc
I		DIG. COMM. DIGITAL COMMUNICATION (ONLY)
Z		SPECIFY
COMMUNICATION / BAUDRATE		
A	0	ANALOG I/O AND RS 232 & 9600 BAUD
B*		RS232
C*		RS485
D	0	PROFIBUS-DP (PNO CERTIFIED , 831-A-023 and 541-C-068-AAG)
E	0	PROFIBUS-DP (<u>not</u> CERTIFIED, 831-A-021 and 541-C-062-AAG)
F*		CARDEDGE CONNECTOR (ONLY 0-5 I/O & COMMUNICATION)
G*		CARDEDGE CONNECTOR (ONLY 0-5 I/O & COMMUNICATION) RS-232
H*		CARDEDGE CONNECTOR (ONLY 0-5 I/O & COMMUNICATION) RS-485
	*1	38400 Baud
	*2	19200
	*3	9600
	*4	7200
	*5	4800
	*6	3600
	*7	2400 * BOTH HAVE TO BE SPECIFIED
	*8	1200
INTERCONNECTION CABLE		
A		NO CABLE
B		MATING CONNECTOR ONLY
C		3m ROUND CABLE
D		6m ROUND CABLE
E		3m ROUND CABLE INCLUDING COMMUNICATION CABLE
F		6m ROUND CABLE INCLUDING COMMUNICATION CABLE
Z		SPECIFY
ENHANCEMENTS		
A		STANDARD RESPONSE:< 1 SEC (5850/51) < 3 SEC (5853) [1].
B		FAST RESPONSE (SPECIFY VALUES SEC.) [1]
C		LINEAR RAMP (SPECIFY VALUES%/SEC.) [1]
D		FLOW OUTPUT DAMPING (SPECIFY VALUES SEC.) [1]

Installation and Operation Manual

X-DPT-Profibus-DP-Interface-eng

PN 541-C-068-AAG

November, 2008

CALIBRATION	
0	UNCALIBRATED DEDUCT
1	STANDARD CALIBRATION INCLUDED
2	STORAGE OF MULTIPLE CAL. CURVES; ADD PER AVAILABLE CALIBRATION GAS
9	SPECIFY
POWER SUPPLY INPUT	
A	± 15 Vdc
B	+ 24 Vdc = (Standard selection)
C	+ 15 Vdc only
Z	SPECIFY
AREA CLASSIFICATION	
1	SAFE AREA
2	CERTIFIED FOR USE IN ZONE 2
9	SPECIFY

5850S/BC 1H A 1 A B3 C A 1 B 1 = TYPICAL MODEL NUMBER

Installation and Operation Manual

X-DPT-Profibus-Interface-eng

PN 541-C-068-AAG

November, 2008

Modellisting Model MF Series

BROOKS MF-SERIES	
SMART MASS FLOW METERS / CONTROLLERS	
BASE MODEL NUMBER	DESCRIPTION
MF60S/AA	MASS FLOW METER; F.S. FLOWRANGES: 0.003 - 0.008 l/min.
MF60S/AC	MASS FLOW METER; F.S. FLOWRANGES: 0.008 - 30 l/min.
MF61S/AD	MASS FLOW METER; F.S. FLOWRANGES: 20 - 100 l/min.
MF63S/AE	MASS FLOW METER; F.S. FLOWRANGES: 100 - 200 l/min.
MF63S/AF	MASS FLOW METER; F.S. FLOWRANGES: 200 - 300 l/min.
MF63S/AG	MASS FLOW METER; F.S. FLOWRANGES: 300 - 400 l/min.
MF63S/AH	MASS FLOW METER; F.S. FLOWRANGES: 400 - 500 l/min.
MF63S/AJ	MASS FLOW METER; F.S. FLOWRANGES: 500 - 600 l/min.
MF63S/AK	MASS FLOW METER; F.S. FLOWRANGES: 600 - 700 l/min.
MF63S/AL	MASS FLOW METER; F.S. FLOWRANGES: 700 - 800 l/min.
MF63S/AM	MASS FLOW METER; F.S. FLOWRANGES: 800 - 900 l/min.
MF63S/AN	MASS FLOW METER; F.S. FLOWRANGES: 900 - 1000 l/min.
MF64S/AO	MASS FLOW METER; F.S. FLOWRANGES: 18 - 80 m ³ /h. (1,5")
MF64S/AP	MASS FLOW METER; F.S. FLOWRANGES: 60 - 140 m ³ /h. (2")
MF64S/AR	MASS FLOW METER; F.S. FLOWRANGES: 140 - 320 m ³ /h. (3")
MF64S/AS	MASS FLOW METER; F.S. FLOWRANGES: 240 - 540 m ³ /h. (4")
MF64S/AT	MASS FLOW METER; F.S. FLOWRANGES: 540 - 1250 m ³ /h. (6") [2D]
MF64S/AU	MASS FLOW METER; F.S. FLOWRANGES: 970 - 2160 m ³ /h. (8") [2D]
MF50S/AA	MASS FLOW CONTROLLER; F.S. FLOWRANGES: 0.003 - 0.008 l/min.
MF50S/AC	MASS FLOW CONTROLLER; F.S. FLOWRANGES: 0.008 - 30 l/min.
MF51S/AD	MASS FLOW CONTROLLER; F.S. FLOWRANGES: 20 - 100 l/min.
MF53S/AE	MASS FLOW CONTROLLER; F.S. FLOWRANGES: 100 - 200 l/min.
MF53S/AF	MASS FLOW CONTROLLER; F.S. FLOWRANGES: 200 - 300 l/min.
MF53S/AG	MASS FLOW CONTROLLER; F.S. FLOWRANGES: 300 - 400 l/min.
MF53S/AH	MASS FLOW CONTROLLER; F.S. FLOWRANGES: 400 - 500 l/min.
MF53S/AJ	MASS FLOW CONTROLLER; F.S. FLOWRANGES: 500 - 600 l/min.
MF53S/AK	MASS FLOW CONTROLLER; F.S. FLOWRANGES: 600 - 700 l/min.
MF53S/AL	MASS FLOW CONTROLLER; F.S. FLOWRANGES: 700 - 800 l/min.
MF53S/AM	MASS FLOW CONTROLLER; F.S. FLOWRANGES: 800 - 900 l/min.
MF53S/AN	MASS FLOW CONTROLLER; F.S. FLOWRANGES: 900 - 1000 l/min.
MECHANICAL CONNECTIONS	
1A	WITHOUT ADAPTORS (9/16"-18" UNF) (ONLY FOR 5850/60/51/61/53/63)
1B	1/4" TUBE COMPRESSION FITTINGS (ONLY FOR 5850/60/51/61)
1C	1/8" TUBE COMPRESSION FITTINGS (ONLY FOR 5850/60/51/61)
1D	3/8" TUBE COMPRESSION FITTINGS (ONLY FOR 5851/61)
1E	1/4" VCR (ONLY FOR 5850/60/51/61)
1F	1/4" VCO (ONLY FOR 5850/60/51/61)
1G	1/4" NPT (ONLY FOR 5850/60/51/61)
1H	6mm TUBE COMPRESSION FITTINGS (ONLY FOR 5850/60/51/61)
1J	10mm TUBE COMPRESSION FITTINGS (ONLY FOR 5850/60/51/61)
1K	1/4" BSP (F) (ONLY FOR 5850/60/51/61)
1Y	1/2" BSP (F) (ONLY FOR 5853/63)
1Z	1" BSP (F) (ONLY FOR 5853/63)

2A		1 1/16" - 12SAE/MS	(ONLY FOR 5853/63)
2B		1/2" TUBE COMPRESSION FITTINGS	(ONLY FOR 5850/60/51/61/53/63)
2C		3/4" TUBE COMPRESSION FITTINGS	(ONLY FOR 5853/63)
2D		1" TUBE COMPRESSION FITTINGS	(ONLY FOR 5853/63)
2E		1/2" NPT(F)	(ONLY FOR 5853/63)
2F		1" NPT(F)	(ONLY FOR 5853/63)
2G		1 1/2" NPT(F) (SEE OPTION "E")	(ONLY FOR 5853/63/64)
2H		1/2" VCO (200 ln/min. max.)	(ONLY FOR 5850/60/51/61/53/63)
2J		3/4" VCO	(ONLY FOR 5853/63)
2K		1/2" VCR (200 ln/min. max.)	(ONLY FOR 5850/60/51/61/53/63)

BROOKS MF-SERIES SMART MASS FLOW METERS / CONTROLLERS			
BASE MODEL NUMBER		DESCRIPTION	
MECHANICAL CONNECTIONS			
2L		DIN DN15PN40	(ONLY FOR MF53/63)
2M		DIN DN25PN40	(ONLY FOR MF53/63)
2N		DIN DN40PN40	(ONLY FOR MF53/63)
2O		DIN DN50PN40	(ONLY FOR MF53/63)
2P		ANSI 1/2" 150 LBS	(ONLY FOR MF53/63)
2R		ANSI 1/2" 300 LBS	(ONLY FOR MF53/63)
2S		ANSI 1" 150 LBS	(ONLY FOR MF53/63)
2T		ANSI 1" 300 LBS	(ONLY FOR MF53/63)
2U		ANSI 1 1/2" 150 LBS	(ONLY FOR MF53/63)
2V		ANSI 1 1/2" 300 LBS	(ONLY FOR MF53/63)
2W		ANSI 2" 150 LBS	(ONLY FOR MF53/63)
2X		ANSI 2" 300 LBS	(ONLY FOR MF53/63)
2Y		1" VCO	(ONLY FOR 5853/63)
2Z		3/4" VCR	(ONLY FOR 5853/63)
3A		2"NPT (SEE OPTIONS B)	(MF5864 ONLY)
3B		ANSI 3" - 150 LBS	(MF5864 ONLY)
3C		ANSI 3" - 300 LBS	(MF5864 ONLY)
3D		ANSI 3" - 600 LBS [2D]	(MF5864 ONLY)
3E		DIN DN80 - PN40 [2D]	(MF5864 ONLY)
3F		DIN DN80 - PN64 [2D]	(MF5864 ONLY)
3G		DIN DN80 - PN100 (MAX. 85 BAR) [2D]	(MF5864 ONLY)
4A		ANSI 4" - 150 LBS	(MF5864 ONLY)
4B		ANSI 4" - 300 LBS	(MF5864 ONLY)
4C		ANSI 4" - 600 LBS [2D]	(MF5864 ONLY)
4D		DIN DN100 - PN16 [2D]	(MF5864 ONLY)
4E		DIN DN100 - PN40 [2D]	(MF5864 ONLY)
4F		DIN DN100 - PN64 [2D]	(MF5864 ONLY)
5A		6" ANSI - 150 LBS [2D]	(MF5864 ONLY)
5B		6" ANSI - 300 LBS [2D]	(MF5864 ONLY)
5C		6" ANSI - 600 LBS [2D]	(MF5864 ONLY)
5D		DIN DN 150 - PN 16 [2D]	(MF5864 ONLY)
5E		DIN DN 150 - PN 40 [2D]	(MF5864 ONLY)
5F		DIN DN 150 - PN 64 [2D]	(MF5864 ONLY)

Installation and Operation Manual

X-DPT-Profibus-Interface-eng

PN 541-C-068-AAG

November, 2008

6A		ANSI 8" - 150 LBS [2D]	(MF5864 ONLY)
6B		ANSI 8" - 300 LBS [2D]	(MF5864 ONLY)
6C		DIN DN200 - PN10 [2D]	(MF5864 ONLY)
6D		DIN DN200 - PN16 [2D]	(MF5864 ONLY)
6E		DIN DN200 - PN25 [2D]	(MF5864 ONLY)
6F		DIN DN200 - PN64 [2D]	(MF5864 ONLY)
9Z		SPECIFY	
O-RING/VALVE SEAT MATERIAL			
A		VITON	
B		BUNA (NOT FOR MF5853)	
C		PTFE/KALREZ (KALREZ FOR SENSOR O-RINGS AND VALVE SEAT) [2D]	
D		KALREZ (NOT FOR MF5853) [2D]	
E		PTFE/EPDM (EPDM ONLY FOR VALVE SEAT) [2D]	
F		PTFE [2D]	
Z		SPECIFY	
VALVE TYPE			
0		METER ONLY (NO VALVE)	
1		NORMALLY CLOSED (MF5850/51 SERIES)	
2		NORMALLY CLOSED (PRESS.DIFF. >2BAR. MF5853 SERIES)	
3		NORMALLY CLOSED (PRESS.DIFF. <2BAR. MF5853 SERIES)	
4		NORMALLY OPENED (MF5850 ONLY)	
9		SPECIFY	

BROOKS MF-SERIES SMART MASS FLOW METERS / CONTROLLERS

BASE MODEL NUMBER		DESCRIPTION	
ELECTRICAL INPUT/OUTPUT			
		INPUT	OUTPUT
A		0-5Vdc	0-5 Vdc & 0-20mA (INCL. RS 232, 9600 BDS)
B		4-20mA	4-20 mA & 1-5Vdc (INCL. RS 232, 9600 BDS)
C		0-20 mA	0-20mA & 0-5Vdc (INCL. RS 232, 9600 BDS)
D		1-5Vdc	1-5 Vdc & 4-20mA (INCL. RS 232, 9600 BDS)
E		DIG. COMM.	DIG. COMM. + 0 - 5 Vdc
F		DIG. COMM.	DIG. COMM. + 4 - 20 mA
G		DIG. COMM.	DIG. COMM. + 0 - 20 mA
H		DIG. COMM.	DIG. COMM. + 1 - 5 Vdc
I		DIG. COMM.	DIGITAL COMMUNICATION (ONLY)
Z		SPECIFY	
COMMUNICATION / BAUDRATE			
A0		ANALOG I/O ONLY AND RS 232 & 9600 BAUDS	
B*		RS232	
C*		RS485	
D0		PROFIBUS-DP (PNO CERTIFIED, 831-A-023 and 541-C-068-AAG)	
*1		38400 Baud	
*2		19200	
*3		9600	
*4		7200	
*5		4800	
*6		3600	
*7		2400	* BOTH HAVE TO BE SPECIFIED
*8		1200	

ELECTRICAL CONNECTION	
K	PG11 CABLE GLAND
L	1/2" NPT ADAPTER CONDUIT ENTRY
Z	SPECIFY
ENHANCEMENTS	
A	STANDARD RESPONSE:< 1 SEC (5850/51) < 3 SEC (5853) [1].
B	FAST RESPONSE (SPECIFY VALUES SEC.) [1]
C	LINEAR RAMP (SPECIFY VALUES%/SEC.) [1]
D	FLOW OUTPUT DAMPING (SPECIFY VALUES SEC.) [1]
ENHANCEMENTS	
0	UNCALIBRATED DEDUCT
1	STANDARD CALIBRATION INCLUDED (SEE OPTION C)
2	STORAGE OF MULTIPLE CAL. CURVES; ADD PER AVAILABLE CALIBRATION GAS
9	SPECIFY
POWER SUPPLY INPUT	
B	+ 24 Vdc = (Standard selection)
Z	SPECIFY
AREA CLASSIFICATION	
1	SAFE AREA [2D]
2	CERTIFIED FOR USE IN ZONE 2 [2D]
3	UL LISTED (NPT ENTRY) (ONLY MF64)
4	UL RECOGNIZED (PG11 ENTRY) (ONLY MF64)
5	WELDED SENSOR, NO CERT, (NPT ENTRY) (ONLY MF64) [2D]
6	WELDED SENSOR, NO CERT, (PG11 ENTRY) (ONLY MF64) [2D]
9	SPECIFY

MF50S / A C 1 H C 1 B A 0 K C 1 B 2 = TYPICAL MODEL NUMBER

Appendix A PROFIBUS-DP message services

A.1 Global control commands

The Profibus standard provides the possibility to issue global command to one or more slave devices. These commands are pre-defined bit mapped commands in the global command data byte, and both the Smart Mass Flow Meter and Controller models will support two of these commands.

Sending a global command involves the use of the global station address, number 127 as well as the group address, set at parameterization. Both devices will support the fail- safe option as well as the sync/unsync option. Both will not support the freeze/unfreeze option. Refer to EN 50170, part 3, section 8.3.7: *Control commands to DP-slave* for a detailed description of this command and the features.

A.2 Fail-safe option

Both device types will support the fail-safe option. This feature allows a global clearing of output data by a Clear-data command, which may be send by the master to all or to a selected group of devices if a network failure is detected by the master. If bit 1 = Clear-data is set in the global command data byte, the device will enter the fail-safe mode, i.e. it will accept the next data exchange request messages if they have no data bytes. The device behaviour to this must pre-programmed. A device will leave the fail-safe mode if a data exchange request is received with valid data bytes or if a global control command is received with bit 1 in the data byte cleared.

The failsafe parameter applies to Smart Mass Flow Controller only. Through this parameter the user can select the type of failsafe of the MFC in case of bus failure or a global 'Clear' command. The failsafe state determines how the MFC is acting if in previous described situations no setpoint value is coming through anymore. Per default the unit is using selection 1 and internally reset its setpoint value to zero and makes the valve powerless. The latter means that a mechanical normally closed valve closes and a mechanical normally open valve opens. This is identical to the situation when the MFC loses its power supply.

In the last two selections the valve can be forced in a position in spite of the mechanical construction.

The first option, 'no effect', means that the MFC is continuing controlling flow using the last setpoint which was sent over the profibus network or, in case of setpoint source is set to analogue, continues flowing the analogue setpoint value.

A Smart Mass Flow Meter will simply accept the no-data messages with no special change in behaviour, i.e. it will continue to accept (empty) data exchange requests and it will continue to respond with measurement data. This does not depend on whether any of the parameters in the request message has been enabled or not.

A.3 Sync/unsync option

In addition both device model types will support the sync/unsync option. This feature allows a global, synchronized processing of the latest entered output data. If the Sync bit is set in the global command data byte, the device will still accept data exchange request message with valid data bytes, but they will not be processed internally. A succeeding message with non-zero contents will overwrite the previous entered data, but the data is still not processed. Upon reception of a global control command with the Unsync bit set, the last entered values will be processed. The sync/unsync cycle applies only to the data bytes entered through the data exchange request message, i.e. disabled parameters are not effected.

For a Smart Mass Flow Meter this command only applies to the command byte (if enabled). The sync/unsync feature allows (e.g.) an application start or stop a number of totalizers at the same time.

E.g. the Sync bit is set in a global control command message, any subsequent setpoint entered through the network will not be processed. Up on the reception of global control command message with the Unsync bit set, the last entered setpoint will be processed. This allows a gas flow application, involving multiple Mass Flow Controllers to synchronize the flow of gas in a process chamber.

NOTE:

The sync/unsync command only applies to the data entered or set through data exchange request message. It does NOT apply to the analogue entered setpoint or valve override command.

Appendix B IEEE 754 Floating Point Format

Our products uses in most cases floating points as input and output parameters. These floating points are defined as IEEE 754 32-bit single precision types. This means that each parameter of a floating point type uses four hexadecimal bytes. These four bytes represents the sign, the exponent and the mantissa.

- A sign bit is used so that both positive and negative numbers could be represented
- An exponent is used to create a large range of values
- A mantissa is used to get an acceptable resolution of the values

Because the exponent value can differ, the logical place of the decimal point, will float. Hence the name floating point. Don' worry about these hexadecimal representation of the floating points. You never should translate this hexadecimal values manual into more readable values. This is done inside your PLC or other destination device. You should only declare variables from type REAL or SHORT in your software, that's all.

But when you do some tracing stuff on profibus for some reason, you will see the raw hexadecimal bytes in the messages on the bus. That's hard to translate, see for example this picture below:

```
000122 16:07:45,036336 0 68 08 08 68 42 02 7d 00 00 00 00 00 c1 16
000123 16:07:45,053628 0 68 18 18 68 02 42 00 00 00 00 00 00 00 41 87 6c 50
000126 16:07:45,117170 0 68 08 08 68 42 02 42 0c 00 00 00 00 ef 16
```

"mfc66r".setpoint	REAL	35.0	00 0f 16
"mfc66r".flow	REAL	35.00076	00 00 00 00 41 87 6c 50
"mfc66r".temp	REAL	17.77982	00 ef 16
"mfc66r".totalizer	REAL	0.0	
"mfc66r".valve	DEC	1#13005	
"mfc66r".cmd			

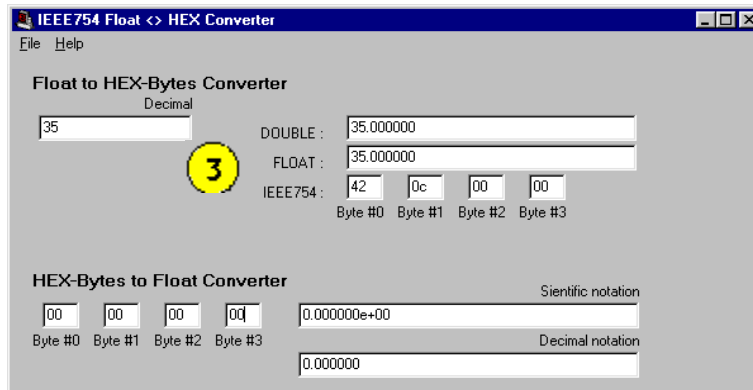

Number 1 indicates a raw bustrace. You'll find in this example at setpoint position the hexadecimal codes '42 0c 00 00'on the bus. Number 2 shows that the setpoint for our device at that moment was, 35.0 decimal. We can verify this hexadecimal codes with a special converter program, called ieee754 Float <-> HEX Converter. This program can be arranged by your sales representative or taken from our website.

LIMITED WARRANTY

Seller warrants that the Goods manufactured by Seller will be free from defects in materials or workmanship under normal use and service and that the Software will execute the programming instructions provided by Seller until the expiration of the earlier of twelve (12) months from the date of initial installation or eighteen (18) months from the date of shipment by Seller.

Products purchased by Seller from a third party for resale to Buyer ("Resale Products") shall carry only the warranty extended by the original manufacturer.

All replacements or repairs necessitated by inadequate preventive maintenance, or by normal wear and usage, or by fault of Buyer, or by unsuitable power sources or by attack or deterioration under unsuitable environmental conditions, or by abuse, accident, alteration, misuse, improper installation, modification, repair, storage or handling, or any other cause not the fault of Seller are not covered by this limited warranty, and shall be at Buyer's expense.

Goods repaired and parts replaced during the warranty period shall be in warranty for the remainder of the original warranty period or ninety (90) days, whichever is longer. This limited warranty is the only warranty made by Seller and can be amended only in a writing signed by an authorized representative of Seller.

BROOKS SERVICE AND SUPPORT

Brooks is committed to assuring all of our customers receive the ideal flow solution for their application, along with outstanding service and support to back it up. We operate first class repair facilities located around the world to provide rapid response and support. Each location utilizes primary standard calibration equipment to ensure accuracy and reliability for repairs and recalibration. The primary standard calibration equipment to calibrate our flow products is certified by our local Weights and Measures Authorities and traceable to the relevant International Standards.

Visit www.BrooksInstrument.com to locate the service location nearest to you.

START-UP SERVICE AND IN-SITU CALIBRATION

Brooks Instrument can provide start-up service prior to operation when required.

For some process applications, where ISO-9001 Quality Certification is important, it is mandatory to verify and/or (re)calibrate the products periodically. In many cases this service can be provided under in-situ conditions, and the results will be traceable to the relevant international quality standards.

CUSTOMER SEMINARS AND TRAINING

Brooks Instrument can provide customer seminars and dedicated training to engineers, end users and maintenance persons. Please contact your nearest sales representative for more details.

HELP DESK

In case you need technical assistance:

- Americas ☎ 1-888-554-FLOW
- Europe ☎ +(31) 318 549 290 Within Netherlands ☎ 0318 549 290
- Asia ☎ +011-81-3-5633-7100



Due to Brooks Instrument's commitment to continuous improvement of our products, all specifications are subject to change without notice.

TRADEMARKS

- Brooks Brooks Instrument, LLC
- Buna DuPont Dow Elastomers
- Kalrez DuPont Dow Elastomers
- Teflon E.I. DuPont de Nemours & Co.
- Viton DuPont Performance Elastomers

Brooks Instrument
 407 West Vine Street
 P.O. Box 903
 Hatfield, PA 19440-0903 USA
 T (215) 362-3700
 F (215) 362-3745
 E-Mail BrooksAm@BrooksInstrument.com
www.BrooksInstrument.com

Brooks Instrument
 Neonstraat 3
 6718 WX Ede, Netherlands
 T 31-318-549-300
 F 31-318-549-309
 E-Mail BrooksEu@BrooksInstrument.com

Brooks Instrument
 1-4-4 Kitasuna Koto-Ku
 Tokyo, 136-0073 Japan
 T 011-81-3-5633-7100
 F 011-81-3-5633-7101
 E-Mail BrooksAs@BrooksInstrument.com